



RR 350 - 400 - 450 - 498

Thanks for your preference, and have a good time! This handbook contains the information you need to properly operate and maintain your motorcycle.

The data and specifications provided in this manual does not constitute an engagement on the part of BETAMOTOR S.p.A. BETAMOTOR reserves the right to make any changes and improvements to its models at any moment and without notice.

IMPORTANT

We recommend you to check all the tightenings after the first one or two hours' ride over rough ground. Special attention should be paid to the following parts:

- rear sprocket
- ensure that the footrests are properly fixed
- front/rear brake levers/calipers/discs
- check that the plastics are properly fastened
- engine bolts
- shock absorber bolts/swingarm
- wheel hubs/spokes
- rear frame
- pipe connections
- tensioning the chain

IMPORTANT

For any servicing requirements, please get in contact with Beta-motor's authorized service network.

Operating instructions.....	5
Ecologic guide.....	5
Riding safety.....	6
CHAPTER 1 GENERAL INFORMATION.....	7
Vehicle identification data	8
Delivery.....	8
Load	10
Tyres	10
Steering lock	11
Familiarizing with your vehicle	12
Controls.....	13
Specifications	21
Wiring diagrams RR 4t	25
Electrical devices.....	27
Devices for Euro 3 version.....	28
CHAPTER 2 OPERATION	29
Checks to be performed before each ride	30
Lubricants.....	31
Running-in	31
Starting the engine.....	32
Refuelling.....	33
CHAPTER 3 CHECKS AND MAINTENANCE.....	35
Engine oil circuit.....	36
Motor oil level check.....	36
Changing the engine oil and filters extraction.....	37
Changing the gear and clutch oil	39
Check the level of the front and rear brake fluid and bleeding.....	40
Check the front and rear brake pads.....	42
Check the oil level in the hydraulic clutch and bleeding	43
Fork oil.....	44
Air filter	47
Spark plug	48
Carburetor	50
Coolant.....	51
Drive chain maintenance and wear.....	52
Charging the battery.....	53
Cleaning and checking the vehicle	54
Scheduled maintenance.....	55
Prolonged inactivity.....	57

CHAPTER 4 ADJUSTMENTS	59
Brake adjustment: front lever and brake pedal.....	60
Adjusting the home position of the clutch lever.....	60
Adjusting the handlebars.....	60
Adjusting the throttle control cable.....	61
Checking and adjusting the steering play.....	61
Adjusting the Suspensions: telescopic fork and shock absorber.....	62 ÷ 64
Tensioning the chain.....	64
Idling setting.....	65
CHAPTER 5 REPLACEMENTS	67
Replacing the brake pads: front and rear	68
Replacing the headlight bulbs	70
Replacing the rear optical batch	70
CHAPTER 6 TROUBLESHOOTING	73
INDEX	75

OPERATING INSTRUCTIONS

- The vehicle must be accompanied by: number-plate, registration document, tax disc and insurance.
- Do not carry animals, pets or loose objects that can stick out from the vehicle.
- Riding without a crash helmet is forbidden.
- Always ride with the low beam on.
- Any modifications of the engine or other parts resulting in a power and/or speed increase are punishable by severe sanctions including the confiscation of the vehicle.
- To protect your safety and that of others, always drive carefully and with your helmet on.

WARNING

Any modifications and tampering with the vehicle during the warranty period exempt the manufacturer from all responsibility and invalidate warranty.

ECOLOGIC GUIDE

- Every vehicle powered by an internal combustion engine produces an amount of noise (noise pollution) and gases (air pollution) which varies with the riding style.
- The abatement of noise and air pollution levels is the duty of everybody. Avoid full-throttle starts, sudden acceleration and abrupt braking. This will reduce noise emission as well as the wear and tear of the tyres and mechanical parts, and will also allow a considerable reduction in fuel consumption.

RIDING SAFETY

- Observe the Highway Code.
- Always put on and fasten a homologated helmet.
- Always ride with the low beam on.
- Always keep the crash helmet visor clean.
- Avoid wearing garments with hanging ends.
- Do not keep sharp or brittle objects in your pockets while riding.
- Properly adjust the rearview mirrors.
- Always ride in a seated position, with both hands on the handlebars and both feet on the footrests.
- Always pay attention and do not allow anything to distract you while riding.
- Do not eat, drink, smoke, use a mobile phone, etc. while riding.
- Do not wear headphones to listen to music while riding.
- Never ride abreast with other vehicles.
- Do not tow and avoid being towed by other vehicles.
- Always keep a safe distance from other vehicles.
- Do not sit on the vehicle when it is on its stand.
- Do not start off while the vehicle is on its stand.
- Do not pull out the stand when the vehicle is facing downhill.
- Avoid swaying and wheelies as they are extremely dangerous for your own and other people's safety as well as for your vehicle.
- Always apply both brakes on dry roads with no gravel and sand. Using one brake may be dangerous and cause uncontrolled skidding.
- To reduce the braking distance, always apply both brakes.
- On wet roads and in off-road riding, drive with care and at moderate speed. Take special care in applying the brakes.
- Do not start the engine in closed places.

CONTENTS

CHAPTER 1 GENERAL INFORMATION

Vehicle identification data

Delivery

Load

Tyres

Steering lock

Familiarizing with your vehicle

Controls

Specifications

Wiring diagram

Electrical devices

Euro 3 devices

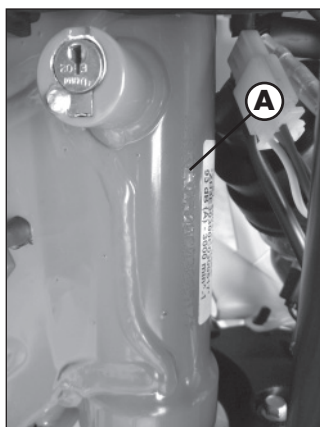

VEHICLE IDENTIFICATION DATA

FRAME IDENTIFICATION

Frame identification data **A** are stamped on the right side of the steering head tube.

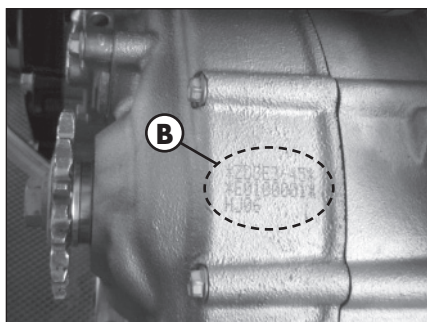

ENGINE IDENTIFICATION

Engine identification data **B** are stamped in the area shown in the figure.

WARNING:

Tampering with the identification numbers is severely punished by law.



DELIVERY

- The vehicle is supplied ready for use. However, it is advisable to conduct a few simple checks before riding:
 - Check the tyre pressures.
 - Check the oil level in the engine.
- The following items are supplied as standard: operation and maintenance manual, tool kit (see photo).

To take the tool kit, push the button **1** to get off the saddle. Pull back the saddle. Pull the rear side panel **2** to disassemble it.

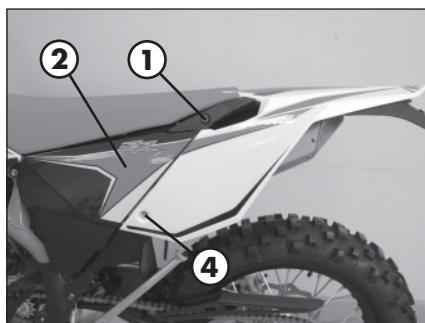

Get off the male end wrenches and hexagon socket **3**. With these is possible to unscrew the screw **4**.

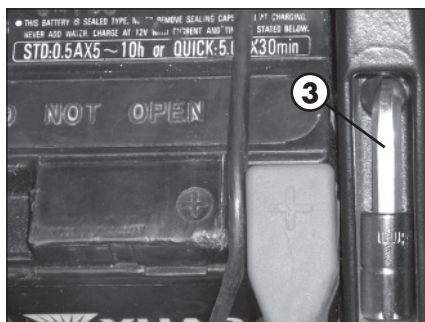

Pull the left cover of rear fender and unhook two rubber bands **5**. Now the toolkit **6** is accessible.

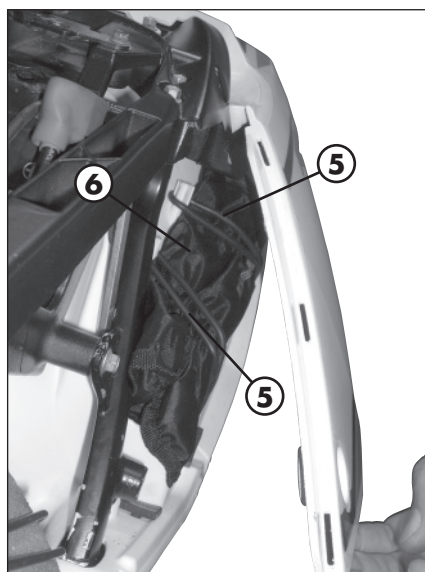

1

LOAD

- To avoid to let the vehicle be unstable, do not carry bulky or heavy objects.
- Do not carry objects that stick from the vehicle or cover the lighting and signalling devices.



TYRES

- Only fit tyres approved by BETAMOTOR. Unsuitable tyres can adversely affect the road holding of the vehicle.
- To protect your safety, immediately replace any damaged tyres.
- Slick tyres adversely affect the road holding of the vehicle, especially on wet roads and in off-road riding.
- Insufficient pressure results in abnormal wear and overheating of the tyres.
- The front and rear tyres must have the same tread design.



pressure is too low



pressure is correct



pressure is too high

TYRES PRESSION ENDURO RR 350 - 400 - 450 - 498

TYRE	front	rear
Off-road	1,0 bar	1,0 bar
Road	1,5 bar	1,8 bar

Note

The type, condition and pressure of the tyres affect the road holding of the vehicle. For this reason it is essential to check them before each journey.

- The size of the tyres is shown in the technical specifications and in the vehicle handbook.
- Check the condition of the tyres before each journey. Inspect the tyres for cuts and for nails or other pointed objects sticking out of them. Regarding the minimum allowable thickness of the tread, observe the regulations in force in your country. We recommend replacing the tyres at the latest when the tread is 2 mm thick.
- Check the inflating pressure on a regular basis while the tyres are cold. Proper pressure ensures optimum riding comfort and prolongs the life of the tyres.

STEERING LOCK

The vehicle is supplied with one key and a spare to be used for the steering lock.

WARNING:

Do not keep the spare keys in the vehicle. Keep the keys in a safe and easy-to-reach place. The code number stamped on the keys should be copied on this manual (or elsewhere) so it can be used to ask for duplicates should both keys be lost.

To engage the steering lock, fully turn the handlebars to the left, insert the key, press and turn it fully anticlockwise and then release it.



1

FAMILIARIZING WITH THE VEHICLE

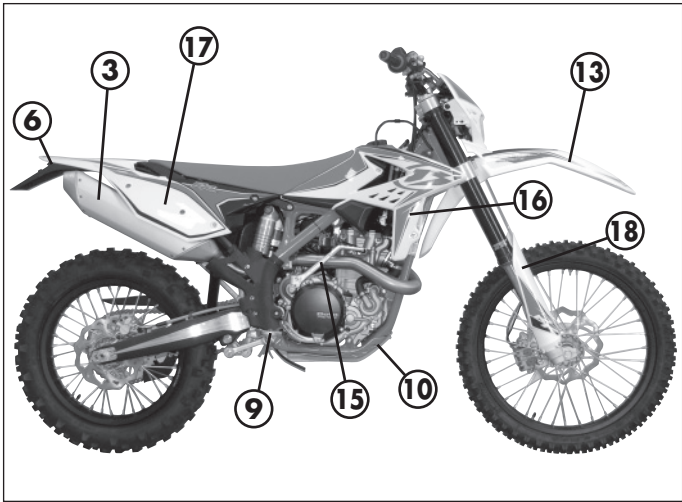
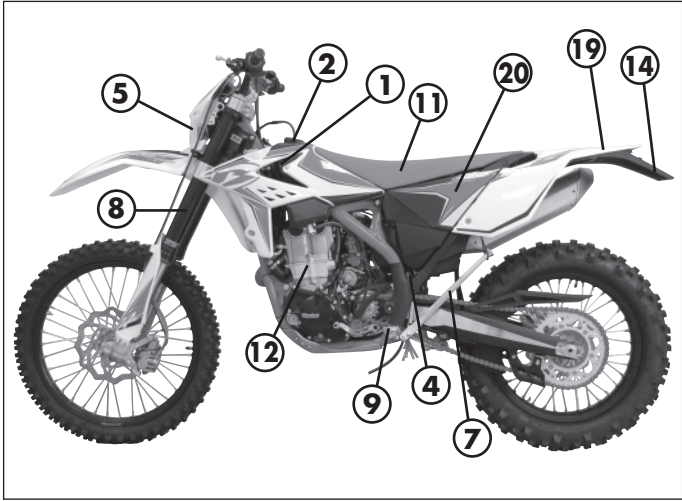

Main parts:

- | | | |
|-------------------------|--------------------------|-----------------------|
| 1 - Fuel tank | 10 - Lower bumper | 18 - Fork covers |
| 2 - Tank cap | (Bumper kit) | 19 - Rear mudguard |
| 3 - Silencer | 11 - Saddle | 20 - Cover air filter |
| 4 - Rear shock absorber | 12 - Engine | |
| 5 - Headlight | 13 - Front mudguard | |
| 6 - Rear light | 14 - Number-plate holder | |
| 7 - Side stand | 15 - Kick-start | |
| 8 - Fork | 16 - Front side panel | |
| 9 - Rider's footrests | 17 - Rear side panel | |

CONTROLS

CLUTCH LEVER

Clutch lever **1** is fitted to the left-hand side of the handlebars. Screw **A** can be used to alter the home position of the lever (see Adjustments).

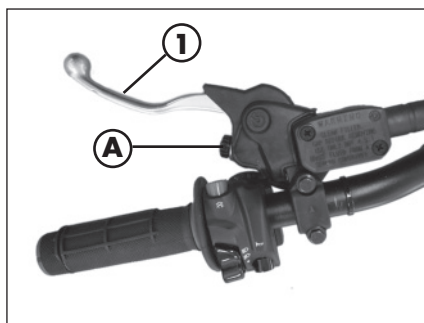

FRONT BRAKE LEVER

Front brake lever **2** is fitted to the right-hand side of the handlebars. Screw **B** can be used to adjust the home position of the lever (see Adjustments).

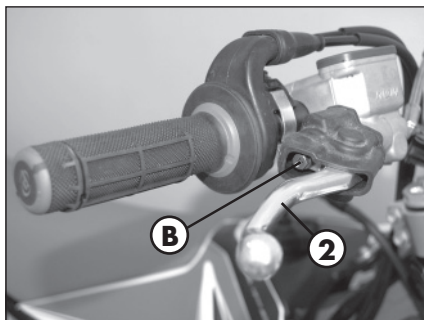

GEARCHANGE LEVER

Gearchange lever **3** is fitted to the left side of the engine. The positions corresponding to the different gears are shown in the figure. The neutral position is between the **1st** and **2nd** gears.

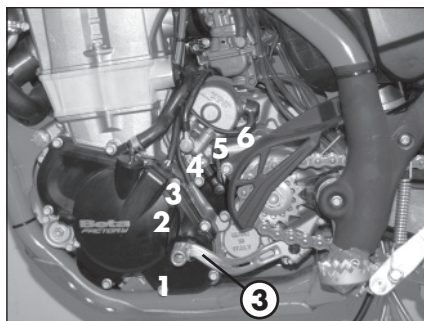

BRAKE PEDAL

Brake pedal **4** is located in front of the right-hand footrest. The position of the pedal can be adjusted to suit the requirements of the driver (see Adjustments).

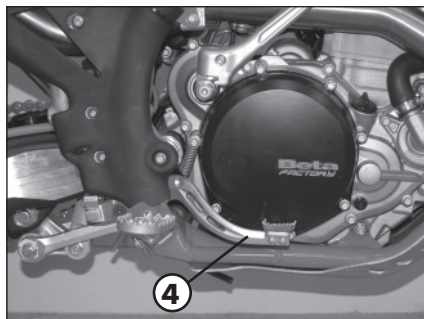

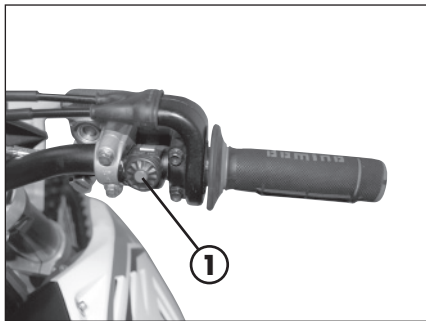

STARTER BUTTON

Starter button **1** is located on the right-hand side of the handlebars and operate the electric engine starter. Push the button until the engine starts. Do not press the button **1** while the engine is running.

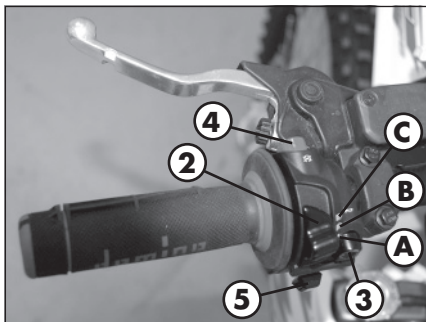

LH SWITCH

Dip switch **2** has three positions:

A = lights off

B = low beam on

C = high beam on

Button **3** operates the horn.

Switch **4** is used to stop the engine. Press the button until the engine stops.

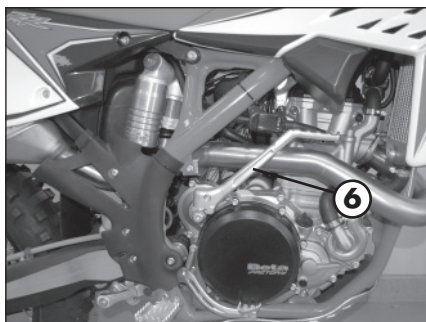

INDICATOR SWITCH

Shifting lever **5** left or right activates the left or right indicators (if installed). When released, the lever returns to the central position. Press it to turn the indicators off.

KICKSTART

Kickstart **6** is fitted to the right-hand side of the engine.

The upper part of the kickstart can be oriented.

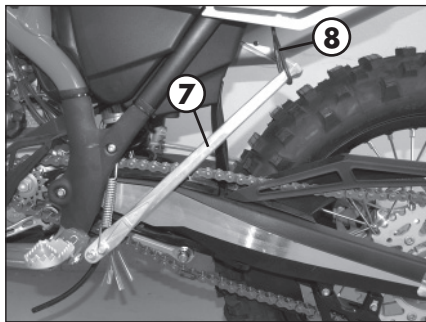

SIDE STAND

Press down side stand **7** with the foot and lean the vehicle against it.

Ensure that the ground is solid and the vehicle stands steadily.

If the vehicle is used off-road, the closed stand can be further fastened by means of rubber band **8**.

DIGITAL RPM INDICATOR

GENERAL SPECIFICATIONS

SPEED/DISTANCE SENSOR: Non-contact magnetic

SCREEN MEASUREMENTS: 125mm x 41mm x 34mm

STORAGE TEMPERATURE: -20°C to 80°C (-4°F to 176°F)

BATTERY: 3V CR2032

BATTERY LIFE: Approximately one year

EXTERNAL CURRENT SUPPLY: 12V DC



GENERAL INFORMATION

Backlight:

The digital speedometer/odometer is backlit to enable reading where there is poor or no lighting.

Using the 12V external current supply (instrument connected to vehicle battery):

- Backlighting is permanent with 12V current supply.
- After 20s of inactivity the backlighting will switch off. To switch it back on press any button or turn the wheel.

Using only the internal battery:

- Backlighting will stay on for 4 seconds before switching off
- With the LO symbol, the backlighting will not switch on. The **LO** symbol appears when the battery voltage is lower than 2.45V.

Reset Button:

Using the Reset button, located on the back of the instrument, all travel data will be deleted, including date and time.

Internal battery:

The instrument houses a 3.0V internal button cell battery (CR2032). The instrument can only work with this battery. The **LO** symbol appears when the battery is running low. To change the battery, unscrew the cap located on the back of the instrument using a coin.

Once the battery has been changed, make sure that the positive side is facing outwards.

REPLACE THE BATTERY WITH ANOTHER CR2032-TYPE BATTERY.

SETTING THE PARAMETERS

General information:

Allowed settings:

- Km/h (kilometres per hour) or M/h (Miles per hour)
- Wheel size (rolling circumference) [mm]
- Clock format: 12-hour / 24-hour
- Current date
- Maintenance

TO ENTER THE PARAMETER SETTINGS MODE HOLD DOWN THE RIGHT AND LEFT BUTTONS FOR APPROX. 3s.

THE WORD "Unit" WILL FLASH ON THE DISPLAY.

The operational logic is structured as follows:

- The instrument enters SETUP mode displaying the parameters according to the sequence listed above.
- The instrument displays the parameter to be changed for a few seconds in flash mode.
- If you wish to change the parameter displayed for those few seconds simply edit the values by pressing the right and/or left buttons (according to the modes listed below), otherwise wait a few seconds (approx. 5 s) to proceed to the next parameter.
- When the parameter has been edited to the desired value, the instrument automatically moves onto the next setting, there is no need to press any button of confirmation.
- If you only wish to enter the setup mode to view the configured settings, simply wait without pressing any buttons; the instrument will display all of the set parameters and will then automatically go back to "Normal Mode".

SETUP SEQUENCE

Select unit of measure

Wheel size

Clock format

Current date

Maintenance

Selecting the unit of measure (Km/h or M/h):

TO SELECT THE UNIT OF MEASURE (Km/h or M/h), PRESS THE RIGHT OR LEFT BUTTON.

WAIT 5 SECONDS TO PROCEED TO THE NEXT SETTING.

DO NOT PRESS ANY BUTTONS.

Selecting the wheel size (rolling circumference):

The instrument has programmed two rolling circumference measurements for the front wheel: 2190mm (Enduro version - 21" rim) or 1890mm (Motard version - 17" rim).

PRESS THE LEFT BUTTON TO SELECT ONE OF THE TWO OPTIONS.

WAIT 5 SECONDS TO PROCEED TO THE NEXT SETTING. DO NOT PRESS ANY BUTTONS.

Selecting the clock format (12- or 24-hour):

The default setting on the instrument is the 12-hour clock.

TO SELECT THE 12- OR 24-HOUR CLOCK, PRESS THE RIGHT OR LEFT BUTTON.

WAIT 5 SECONDS TO PROCEED TO THE NEXT SETTING. DO NOT PRESS ANY BUTTONS.

Setting the Time:

The time is set by increasing or decreasing it by 1 minute steps.

PRESS THE LEFT BUTTON TO DECREASE THE TIME.

PRESS THE RIGHT BUTTON TO INCREASE IT.

WAIT 5 SECONDS TO PROCEED TO THE NEXT SETTING. DO NOT PRESS ANY BUTTONS.

Selecting the maintenance memo 

The instrument displays the countdown to maintenance operations based on the data entered by the user. The data is based on the kilometres and miles travelled according to

the unit of measure selected by the user. The factory setting is on "OFF".

PRESS THE LEFT BUTTON TO LOWER THE NUMBER. PRESS THE RIGHT BUTTON TO RAISE IT (max value 10000).

WAIT 5 SECONDS TO EXIT SETUP MODE.

DO NOT PRESS ANY BUTTONS.

SCREENS

Switching between 3 normal modes

All of the information that the instrument is capable of providing is displayed on one of these 3 screens.

The instrument will stay on the set screen until a button is pressed to switch to another screen.

TO SWITCH FROM ONE SCREEN TO ANOTHER, PRESS EITHER THE RIGHT OR LEFT BUTTON BRIEFLY.

Screen 1:

- Speed • Distance 1 (DST) • Time

Screen 2:

- Speed • Distance 2 (DST2) • Time

Screen 3:

- Maximum speed (MAX) • Average speed (AVG)
- Accumulated running time (ART) • Odometer (ODO)

* Note: The maximum and average speeds are updated automatically when the user accesses screen 3.

FEATURES

General information:

During normal use the instrument is in "Normal" mode.

Available modes:

- Sleep Mode
- Choose from 3 "Normal" screens
- Clear Distance 1 (DST1)
- Clear Distance 2 (DST2)
- Clear Maximum/Average Speed (MAX/AVG)

Sleep Mode:

If the instrument does not receive any input for 5 minutes (either from the movement of the wheel or a button), it will go into "Sleep Mode". In "Sleep Mode" only the time appears on the screen.

To exit "Sleep Mode" all the instrument requires is an input, either from the movement of the sensor or by pressing a button.

SPEEDOMETER

Speed

The speed is displayed in the centre of screens 1 or 2 and can range from 0 to 399.9 km/h or M/h. The unit of measure (km/h or M/h) appears next to the speed reading.



Maximum (Max) and Average (AVG) speed

The Maximum (MAX) or Average (AVG) speeds are displayed on screen 3 to the left of the display. The instrument automatically updates both the maximum (MAX) and average (AVG) speeds. To clear the maximum (MAX) and average (AVG) speeds, hold the right button down for 5 seconds.

Note: you must be on screen 3 to clear the speeds.



ADJUSTING THE TRAVELLED DISTANCE METER

Description

The travelled distance meter displays the distance that has been travelled since it was last cleared. It has two different distinguishing distances.



Travelled distance (DST)

The travelled distance can range from 0 to 9999.9 miles or kilometres and appears on the right side of screen 1. To clear the travelled distance, hold the right button down for 5 seconds.

Note: you must be on screen 1 to clear the travelled distance.



Travelled distance 2 (DST 2)

Travelled distance 2 can range from 0 to 9999.9 miles or kilometres and appears on the right side of screen 2. To clear the travelled distance, hold the right button down for 5 seconds.

Note: you must be on screen 2 to clear the travelled distance.



SPECIFICATIONS

Dry weight RR 350 - 400 113 kg (front 55 Kg; rear 58 Kg)
 Dry weight RR 450 - 498 113,5 kg (front 55 Kg; rear 58,5 Kg)

DIMENSIONS RR 350 - 400 - 450 - 498

maximum length 2180 mm
 maximum width 807 mm
 overall height 1270 mm
 wheelbase 1490 mm
 saddle height 940 mm
 ground clearance 320 mm
 footrest height 413 mm

FRAME molybdenum steel with double cradle split above exhaust port

TYRES

pressure (bar) off-road front 1,0 / rear 1,0
 pressure (bar) road front 1,5 / rear 1,8

WHEEL DIMENSION

front cover 90/90 - 21
 rear cover 140/80 - 18
 front rim 21x1,6 - 36 holes
 rear rim 18x2,15 - 36 holes

CAPACITIES

fuel tank.....	8 liter
fuel type	petrol unleaded, with a minimum octane number of 95 (R.O.N.)
including reserve	1,3 liter
coolant circuit	1,3 liter
motor oil	0,85 liter (15W - 50)
gear oil	1 liter (10W - 40) - about details see page 39

FRONT SUSPENSION

"SACHS" hydraulic upside-down fork (Ø48 mm shafts)

spring	K 4,8
oil type	FUCHS 1091 (SAE 2.5)
oil quantity (from the top, without spring and with fork compressed).....	110 mm

REAR SUSPENSION

Single shock absorber with compound lever

spring	K 5,2
precharge	251 mm ±1,5 mm
shock absorber travel	135 mm
rear wheel travel	290 mm

FRONT BRAKE

Ø 260 mm disc and dual-piston floating caliper

REAR BRAKE

Ø240 mm disc and single-piston floating caliper

ENGINE

Type	Single cylinder, 4-stroke, liquid-cooled with countershaft and electric starting
Bore x stroke RR 350	88 x 57,4 mm
Bore x stroke RR 400	95 x 56,2 mm
Bore x stroke RR 450	95 x 63,4 mm
Bore x stroke RR 498	100 x 63,4 mm
Displacement (cm ³) RR 350	349 cm ³
Displacement (cm ³) RR 400	398 cm ³
Displacement (cm ³) RR 450	449,4 cm ³
Displacement (cm ³) RR 498	497,9 cm ³
Compression ratio RR 350	13,3:1
Compression ratio RR 400	12,4:1
Compression ratio RR 450	11,95:1
Compression ratio RR 498	12,0:1
Carburetor	see table

Version	RR 350		RR 400		RR 450		RR 498	
	Homolog.	Race*	Homolog.	Race*	Homolog.	Race*	Homolog.	Race*
Carburetor type	Keihin FCR/MX 39		Keihin FCR/MX 39		Keihin FCR/MX 39		Keihin FCR/MX 39	
Main jet	168	170	175	175	162	175	175	180
Idling jet	42	40	45	45	45	45	45	45
Starter jet	85	85	85	85	85	85	85	85
Needle	OBDVS	NCVQ	OBDVS	OBDTS	OBEKT	OBDVS	OBDVS	OBDVS
Needle position (from above)	2°	3°	1°	5°	2°	4°	1°	4°
Main air jet	200	200	200	200	200	200	200	200
Idling air jet	100	100	100	100	100	100	100	100
Mixture control screw (from fully closed)	1/4	1 + 1/2	1 + 3/4	1 + 1/2	1	1 + 1/2	1 + 3/4	1 + 1/2
Intake jet	40	40	50	50	40	40	40	40
Stop	YES	NO	YES	NO	YES	NO	YES	NO

* - This change makes the vehicle not complying with the Highway Code. Use should be limited to private circuits and routes closed to traffic.

Lubrication 2 oil pumps

Fuel system.....carburetor

Cooling system forced liquid circulation by pump

Spark plugNGK LKAR 8A - 9

Clutch wet, multidisc

Transmission 6-speed with front claw clutch

	RR 350	RR 400	RR450	RR 498
Primary drive	28/76	28/76	31/73	31/73
Gear ratio 1st gear	12/31	12/31	12/31	12/31
Gear ratio 2nd gear	15/28	15/28	15/28	15/28
Gear ratio 3rd gear	19/28	19/28	19/28	19/28
Gear ratio 4th gear	20/24	20/24	20/24	20/24
Gear ratio 5th gear	27/27	27/27	27/27	27/27
Gear ratio 6th gear	28/24	28/24	28/24	28/24
Final drive	chain			

Valve gear 4 valves

Pinion (omologation) Z 15

Pinion (race use)..... Z 13

Rear sprocket (omologation) 350-400-450-498 cm³..... Z 45

Rear sprocket (race use) 350-400 cm³ Z 50

Rear sprocket (race use) 450-498 cm³ Z 48

Play of valves intake 0,10±0,175 mm
exhaust 0,125±0,20 mm

Ignition DC-CDI without trembler,
with digital variable spark advance, Kokusan-type

Starting electric starter and kickstart

WIRING DIAGRAM RR 4T

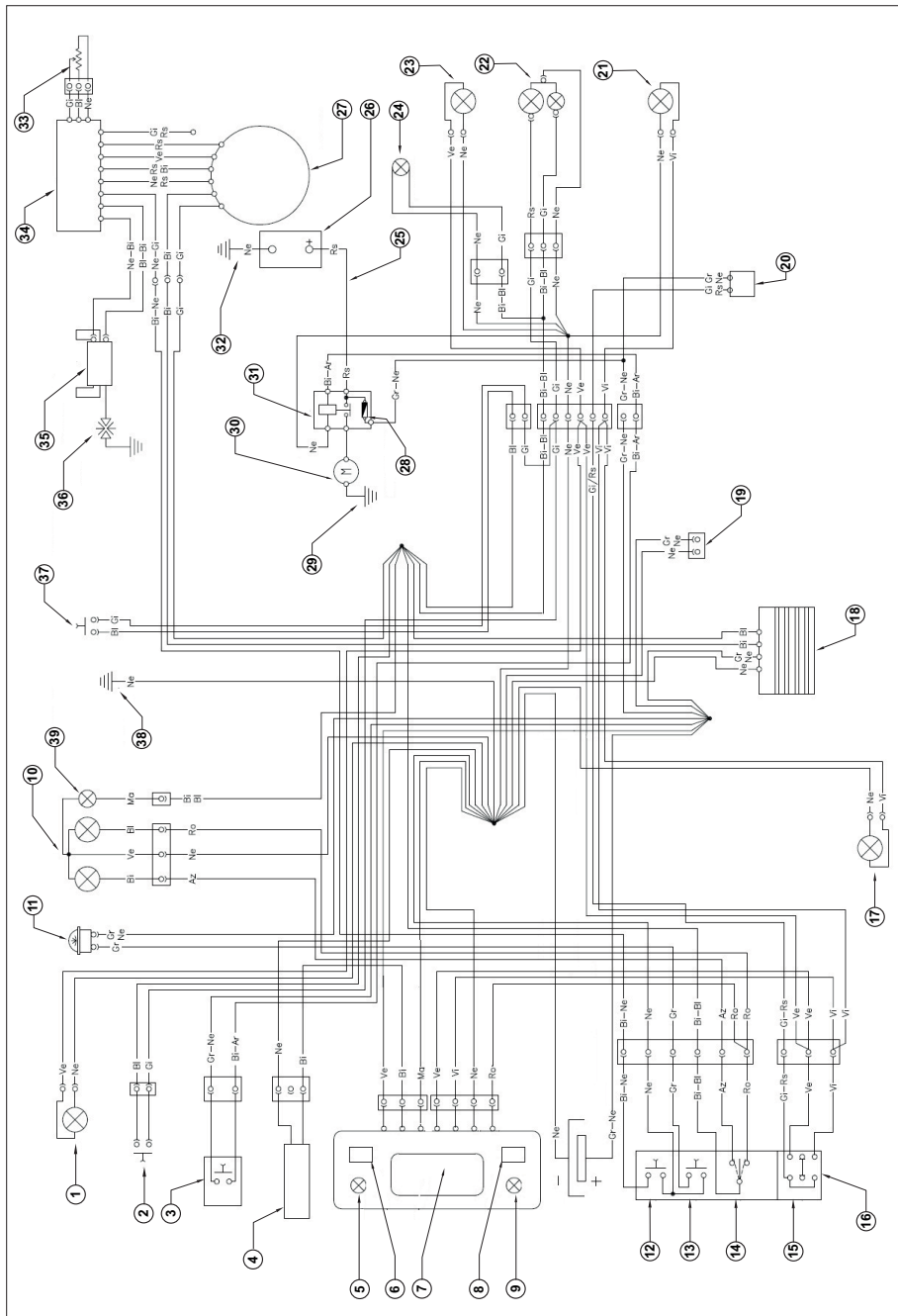

WIRING DIAGRAM RR 4t

- 1) RIGHT-HAND FRONT TURN INDICATOR (12V-10W BULB)
- 2) FRONT BRAKE LIGHT BUTTON
- 3) START BUTTON
- 4) WHEEL REVOLUTION SENSOR
- 5) TRAFFICATOR LIGHTS TELL TALE LAMP
- 6) RIGHT BUTTON
- 7) DISPLAY
- 8) LEFT BUTTON
- 9) HEADLIGHT TELL TALE LAMP
- 10) HEADLIGHT (12V-35/35W BULB)
- 11) 12V HORN
- 12) ENGINE STOP BUTTON
- 13) HORN BUTTON
- 14) HEADLIGHT SELECTOR
- 15) TURN SIGNAL LAMPS SWITCH
- 16) LEFT-HAND CONTROL GROUP
- 17) LEFT-HAND FRONT TURN INDICATOR (12V-10W BULB)
- 18) REGULATOR 12V
- 19) ELECTRIC FAN KIT (OPTION)
- 20) UNIT TURN SIGNAL LAMPS
- 21) LEFT-HAND REAR TURN INDICATOR (12V-10W BULB)
- 22) TAIL LIGHT WITH LED
- 23) RIGHT-HAND REAR TURN INDICATOR (12V-10W BULB)
- 24) NUMBER-PLATE LIGHT
- 25) BATTERY POSITIVE TERMINAL
- 26) BATTERY 12V - 4Ah
- 27) GENERATOR
- 28) 10A FUSE
- 29) FRAME EARTH WIRE
- 30) STARTER MOTOR
- 31) STARTER RELAY
- 32) BATTERY NEGATIVE TERMINAL
- 33) TPS (THROTTLE POSITION SENSOR)
- 34) ELECTRONIC CONTROL UNIT
- 35) HT COIL
- 36) SPARK PLUG
- 37) REAR BRAKE LIGHT BUTTON
- 38) FRAME EARTH
- 39) PARKING LIGHT 12V-5W

Key to colours

Bi = White

Ve = Green

Ma = Brown

Vi = Purple

Bl = Blue

Ne = Black

Gi = Yellow

Rs = Red

Ar = Orange

Az = Sky-blue

Ro = Pink

Gr = Grey

ELECTRICAL DEVICES

BATTERY

Battery **1** is located under the saddle and requires no maintenance.

It is not necessary to check the level of the electrolyte or top up with water.

Keep the battery terminals clean and, if necessary, protect them with a small quantity of vaseline technique.

Removing the battery

Remove the saddle and disconnect the battery. Be sure to disconnect the negative terminal first and then the positive terminal.

Release rubber band **2**.

Remove the battery.

When fitting the battery, insert it with the terminals at the front (see figure). Lastly connect the negative terminal to the battery.

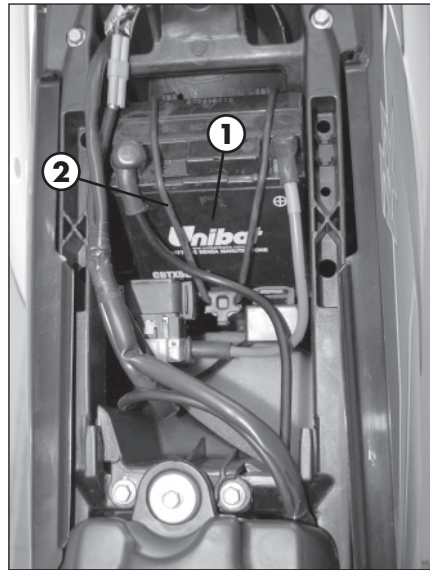

WARNING

To avoid damaging rubber band **2**, take care not to pass it over the edge of the battery.

WARNING

Extreme caution should be exercised if the electrolyte (sulphuric acid) should spill out of the battery. The electrolyte can cause severe burns. In case of contact with the skin, rinse generously with water.

Should the electrolyte come into contact with the eyes, rinse with water for at least 15 minutes and immediately seek medical assistance.

Although the battery is sealed, there is a possibility that explosive gases might leak out.

Keep sparks and open flames away from the battery.

Keep exhausted batteries out of the reach of children and dispose of them as prescribed by law.

Do not remove the protections.

When installing the battery, take care to observe the polarity of the connections.

INACTIVITY

If the vehicle is left unused for a long period, remove the battery and charge it with a suitable charger every 15 days. Keep the battery in a dry place at a temperature of 5-35°C and out of the reach of children.

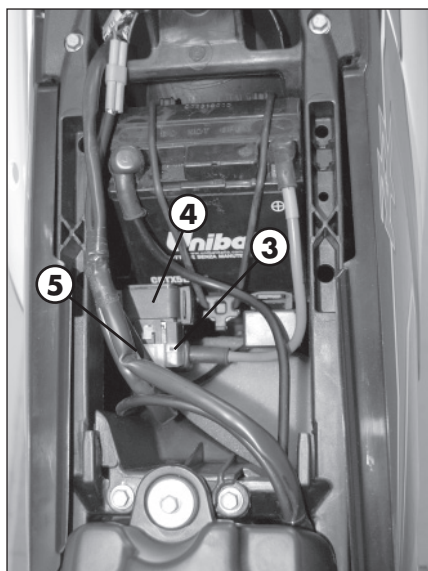

FUSE

Fuse **3** is located in starting relay **4** placed under the saddle and front the battery. To gain access to the fuse remove the saddle.

The fuse protects the following devices:

- electric starter
- horn
- indicators
- instrument panel

The starting relay also contains spare fuse **5** (10 amperes).

Always replace a blown fuse with another of the same type.

If the new fuse should also burn out when fitted, immediately contact a specialized BETAMOTOR workshop.

The fuse has a capacity of 10 amperes.

WARNING

Do not on any account fit a larger capacity fuse or attempt to fix a broken fuse.

Unskilled operations could cause a breakdown of the entire electrical system.

DEVICES FOR E3 VERSION

The latest models are **E3** type-approved and they differ from prior approvals in that two devices have been introduced:

AIS valve

It is called AIS **1** and it is an air intake system which allows to complete the combustion of some unburned fuels remaining from the thermodynamic cycle.

The catalytic converter

The catalytic converter is located in the n°**2** zone, between the two parts of the exhaust pipe. Its function is to reduce the harmful substances present in the exhaust fumes, specifically CO (carbon monoxide), the HC (unburned fuel) and the Nox (nitrogen oxide).

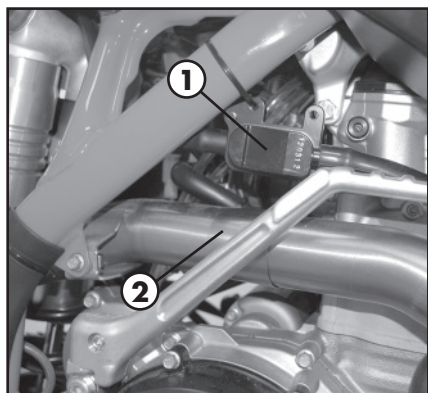

CONTENTS

CHAPTER 2 OPERATION

Checks to be performed before each ride

Lubricants

Running-in

Starting the engine

Refuelling

CHECKS TO BE PERFORMED BEFORE EACH RIDE

The vehicle can be used only if it is in perfect condition from a technical point of view. To ensure maximum safety, it is advisable to carry out a general inspection of the motorcycle before each ride. The checks to be performed are described below.

- 1 CHECK THE ENGINE OIL LEVEL
Insufficient oil levels lead to early wear and, in the long run, to engine damage.
- 2 FUEL
Check the level of the fuel in the tank, arrange the breather pipe so that it has no kinks and fit the fuel tank cap.
- 3 DRIVE CHAIN
A slack chain can come out of the chainring and sprocket. An overtight chain can break or damage the other components of the final drive. A dirty or poorly lubricated chain can cause premature wear of the parts.
- 4 TYRES
Thoroughly check the tyre tread. If a tyre presents cuts or bulges, replace it. The thickness of the tread must be as prescribed by law. Check the tyre pressure. Wear and unsuitable pressure adversely affect road holding.
- 5 BRAKES
Check the operation of the brakes and the level of the brake fluid. If the brake fluid level falls below the minimum, check the brake pads for wear and the braking system for possible leaks. If an oil leak is found, have the braking system overhauled by a specialized BETAMOTOR workshop.
- 6 CABLE CONTROLS
Check the adjustment and the operation of all the cable controls.
- 7 COOLANT
Check the level of the coolant when the engine is cold.
- 8 ELECTRICAL SYSTEM
With the engine running, check the operation of the headlight, the rear and brake lights, the indicators, the warning lights and the horn.
- 9 SPOKES
Check that the spokes are properly tightened.
- 10 NUTS AND BOLTS
Inspect all the nuts and bolts.

Note

Check the presence of the vehicle identification papers.

In cold weather, it is advisable to warm up the engine by letting it idle a few minutes before starting it off. Each time the vehicle is used cross-country, it is necessary to wash carefully, dry it and then lubricate.

LUBRICANTS

To maximize the vehicle's performance and ensure many years of trouble-free operation, we recommend using the following products:

PRODUCT TYPE	SPECIFICATIONS
ENGINE OIL	PANOLIN OFF ROAD 4T RACE 10W/50
GEAR AND CLUTCH OIL	PANOLIN OFF ROAD 4T SYNTH 10W/40
BRAKE OIL	BARDAHL BRAKE FLUID DOT 4
CLUTCH ACTUATOR OIL	BARDAHL BRAKE FLUID DOT4 DOT 5.1
FORK OIL	FUCHS 1091 (SAE 2,5)
TIE ROD GREASE	PANOLIN SPECIAL GREASE NLGI 2
LIQUID COOLANT	PANOLIN ANTI-FROST MT-325

Note

It is essential that all renewals should be performed with the products listed in the table above.

RUNNING-IN

The running-in period lasts approximately 15 hours, during which it is advisable to:

- 1 During the first 3 hours of operation the engine should only be used to approximately 50 percent of its power. In addition, the engine speed should not exceed 7,000 rpm.
- 2 For the next 12 hours of operation the engine should only be used to about 75 percent of its power.
- 3 Use the vehicle after properly warming up the engine.
- 4 Avoid travelling at constant speed (changing the speed causes the different components to bed in evenly and more quickly).

This procedure should be followed each time piston, piston rings, cylinder, crankshaft or crankshaft bearings are replaced.

WARNING

After the first 3 hours or 20 litres of petrol change the engine and gear oil.

- Always use high-octane unleaded petrol.
- After using the vehicle on rough ground for the first time, carefully **check the tightening of all nuts and bolts.**

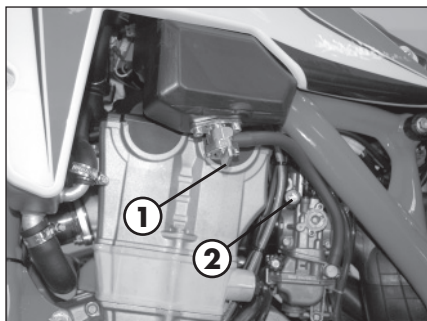

STARTING THE ENGINE

COLD STARTING

- 1 Open fuel cock **1**.
- 2 Take the vehicle off the stand.
- 3 Shift into neutral.
- 4 Operate choke **2** by pulling it until it stops.
- 5 WITHOUT opening the throttle, firmly and FULLY operate kickstart **3** or use the electric starter.
- 6 After a few seconds push the choke **2** inwards in its initial position.

HOT STARTING

- 1 Open fuel cock **1**.
- 2 Take the vehicle off the stand.
- 3 Shift into neutral.
- 4 WITHOUT opening the throttle, firmly and FULLY operate kickstart **3** or use the electric starter.

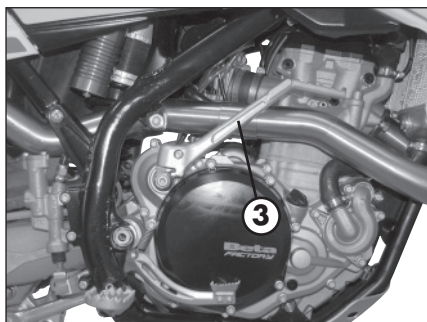

WHAT TO DO IF THE ENGINE IS FLOODED

After a fall, the engine may receive more fuel than is needed. Actuate the kickstart **3**, 5-10 times or press the electric starter button twice for 5 seconds. Subsequently start the engine as described previously.

WARNING

The carburettor is equipped with an accelerating pump.

When starting the engine, do not open the throttle fully more than once as the engine might get flooded.

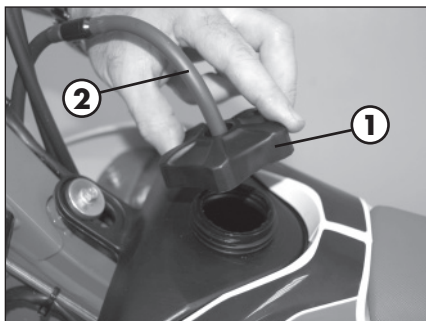

REFUELLING

FUEL TANK CAP

Open: Turn tank cap **1** anticlockwise.

Close: Replace the tank cap and turn it clockwise.

Arrange tank breather pipe **2** so that it forms no kinks.

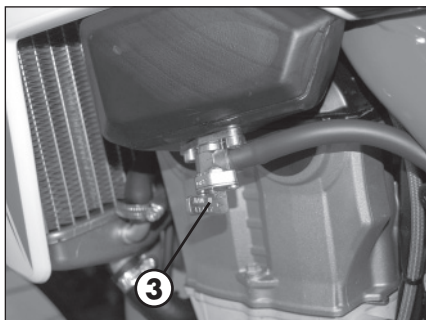

FUEL COCK

OFF Fuel cock **3** is closed.

ON Before using the vehicle, turn the knob to ON. This allows the fuel to flow to the carburettor. When the fuel cock is in the ON position the fuel tank empties until only the reserve fuel is left.

RES The reserve fuel is used only if the knob is in the RES position. Do not forget to bring the knob back to the ON position after refuelling.

Reserve fuel..... 1,3 litres

The fuel tank capacity is approximately 8,0 litres, including 1,3 litres reserve. Immediately wipe off any fuel spills from the bodywork and other parts of the vehicle. Stop the engine before refuelling.

Petrol is highly flammable. Take care not to spill it from the tank while refuelling. Keep open flames and lighted cigarettes away from the tank filler: danger of fire. Avoid inhaling harmful vapours.

Fuel expands under the action of heat. It is therefore recommended not to fill the tank to the brim.

CONTENTS

CHAPTER 3 CHECKS AND MAINTENANCE

Oil Circuit

Motor oil level check

Changing the engine oil and filters extraction

Changing the gear and clutch oil

Check the level of the front and rear brake fluid and bleeding

Check the front and rear brake pads

Check the oil level in the hydraulic clutch and bleeding

Fork oil

Air filter

Spark plug

Carburetor

Coolant

Drive chain maintenance and wear

Charging the battery

Cleaning and checking the vehicle

Scheduled maintenance

Prolonged inactivity

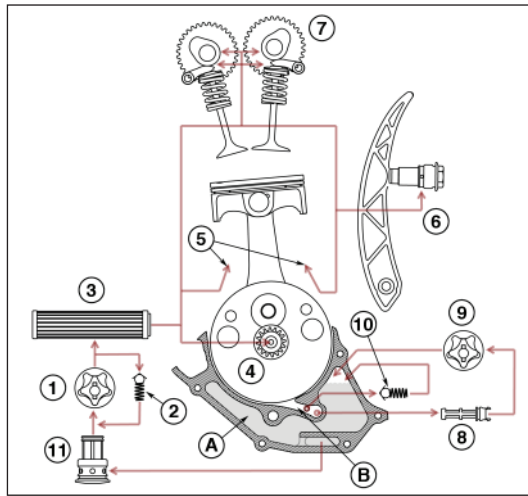

OIL CIRCUIT

The pump **1** (high pressure) push oil to crank mechanism **4**, to piston oil jet **5**, to stretcher **6**, to head jet **7**. The valve **2** control the pressure and the paper filter **3** scrubs the oil from subtle impurity.

When oil has lubricated the head and has pushed the chain stretcher, the oil goes in generator room **A**. When oil has lubricated the crank mechanism and piston-cylinder coupling, goes in the crank mechanism room **B**. Pump **1** sucks the oil from room **B** across the wire netting filter **11** and the pump push the oil to room **A**.

The valve **10** controls the pressure between room **A** and room **B**.

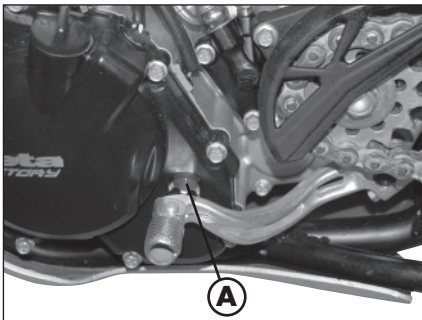

CHECKING THE ENGINE OIL LEVEL

The engine oil level can be checked when the engine is cold or hot.

Place the vehicle in an upright position (not on the side stand) on level ground.

When the engine is cold, the oil should reach the lower edge of sight **A**.

When the engine is hot, the oil should reach the upper edge of the sight.

Top up as necessary.

WARNING

The use of insufficient quantities of oil or of oil of inferior quality results in premature wear of the engine.

CHANGING THE ENGINE OIL AND FILTERS EXTRACTION

Before performing this operation, remove the lower bumper **A**, after underscrewing the three screws **B** as shown in the figure.

Whenever the oil is changed, is necessary to change the paper filter and to clean the wire netting filter.

The oil must be changed when the engine is at operating temperature.

WARNING

When at operating temperature, the engine and the oil it contains are very hot. Take special care to avoid burns.

Park the motorcycle on level ground, remove screw **C** and let the oil drain in a container.

Thoroughly clean the screw and wire netting filter. After the oil has drained completely, clean the sealing surface, replace screw **C** with the seal ring and wire netting filter and tighten at 20 Nm.

In order to let the oil drain it's necessary to unscrew just the screw **C**.

Don't disassemble for any reason screw D which is part of the engine oil pressure adjustment valve.

In case the screw **D** was removed or the spring 42, ball 43, washer 41 were extracted reassemble all the parts following the order showed in attached picture (applying to the screw **D** a torque of 20 Nm).

The working of the engine without one of the mentioned elements would compromise the engine integrity since the engine project conditions would not be respected any more.

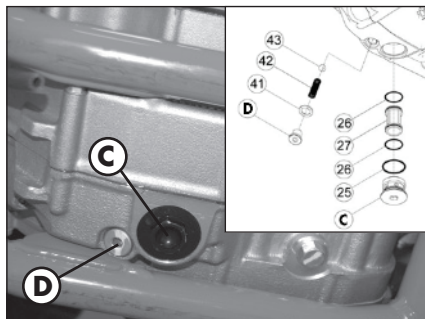
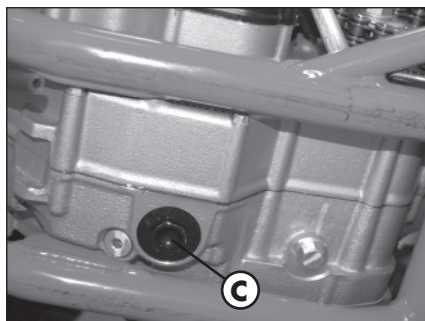
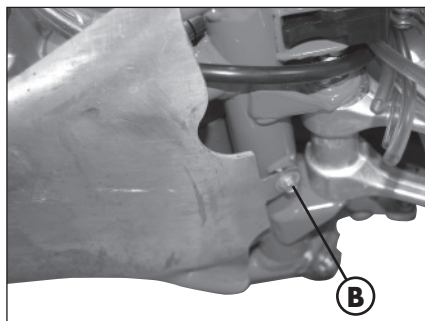
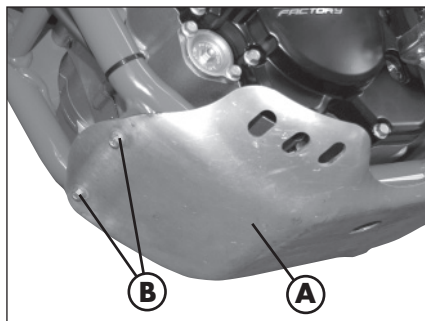

Pressure adjustment valve:

- C** - Oil drain plug
- 25 - O-ring 27x2
- 26 - O-ring 20x1,5
- 27 - Oil filter

- D** - Screw
- 41 - Washer
- 42 - Spring
- 43 - Ball

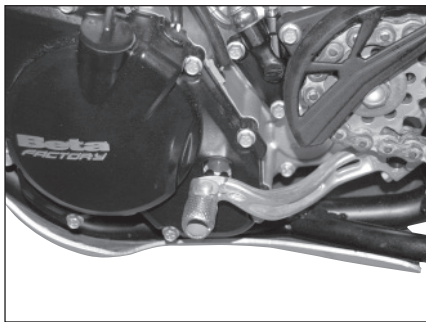
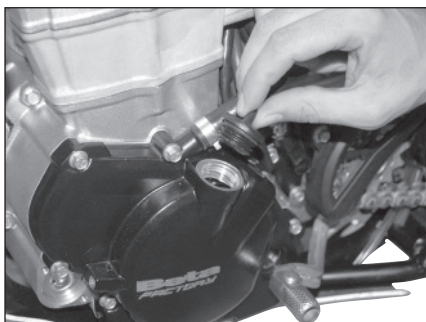
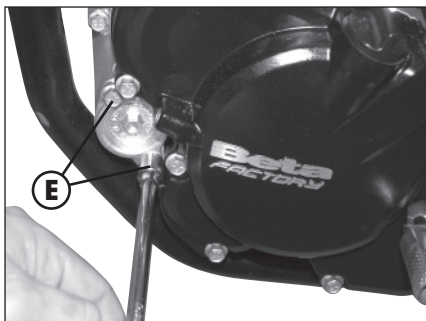

To change the paper filter, remove the oil tap from engine unscrewing the two screws **E**. Using special seeger ring pliers, pull the paper oil filter.

Mount the new paper filter, close the oil tap to engine, tighten the screws at 6 Nm. Remove screw fastener from left carter and pour in 800 ml engine oil PANOLIN OFF ROAD 4T RACE 10W/50. Start the engine and let it idle for five minutes, checking for oil leaks. Stop the engine and after five minutes check the level oil through window.

ATTENTION:
Used oil contains hazardous to the environment. For the replacement must be prepared for disposal in compliance with the law.

CHANGING THE GEAR AND CLUTCH OIL

Before performing this operation, remove the lower bumper **A** after unscrewing the three screws **B** as shown in the picture.

The oil must be changed when the engine is at operating temperature.

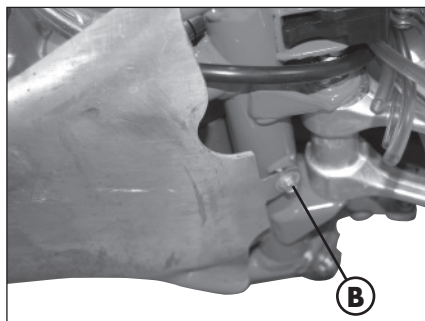
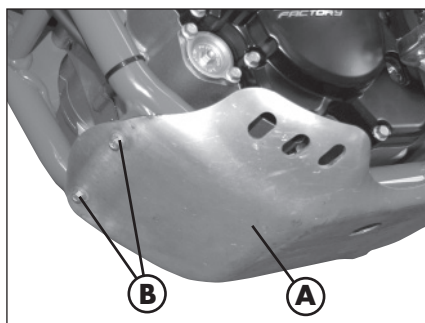

Park the motorcycle on level ground, remove the screw **C** and let oil drain in a container.

Thoroughly clean the screw and sealing surface, put in screw **C** with the seal ring and tighten at 20 Nm.

Remove screw fastener from right carter and pour in gear oil PANOLIN OFF ROAD 4T SYNTH 10W/40. To check the oil level, unscrew the check bolt **D**. The oil level must arrive to the lower edge of check hole. Under conditions with high engine temperatures and intense clutch use (deep sand and mud) it is recommended to use an increased clutch/gearbox oil quantity of 1000 ml.

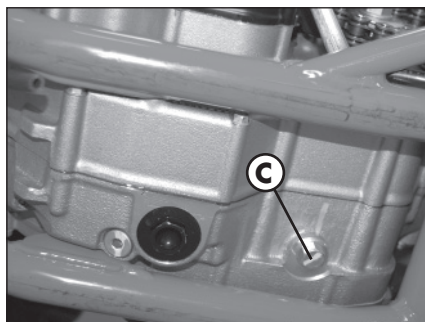

ATTENTION:

To check the gear oil level, it is necessary to use the vehicle for five minutes.

Tighten the check bolt.

ATTENTION:

Used oil contains hazardous to the environment. For the replacement must be prepared for disposal in compliance with the law.

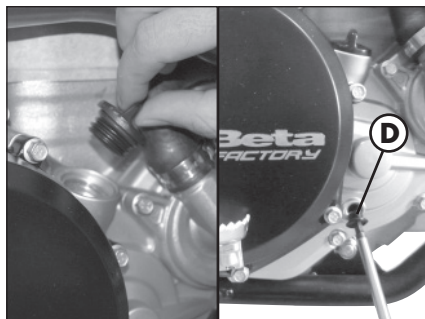

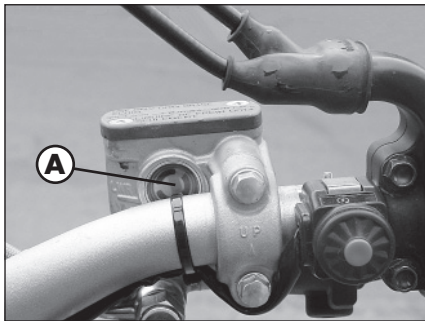

CHECK THE LEVEL OF THE FRONT BRAKE FLUID

Check the level of the brake fluid through sight **A**. The level of the fluid should never fall below the mark in the sight.

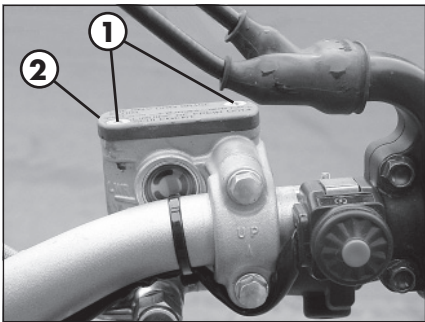

RESTORING THE LEVEL OF THE FRONT BRAKE FLUID

To restore the level of the brake fluid, loosen the two screws **1**, lift cap **2** and add brake fluid (BARDAHL BRAKE FLUID DOT 4) until its level is 5 mm below the upper rim of the reservoir.

WARNING

We recommend using DOT 4 brake fluid. Should this fluid be unavailable, use DOT 5.1 fluid instead. Do not on any account use DOT 5 brake fluid. This is a purple fluid with a base of silicone oil which requires special seals and tubes.

WARNING

The brake fluid is extremely corrosive. Take care not to spill it on the paintwork.

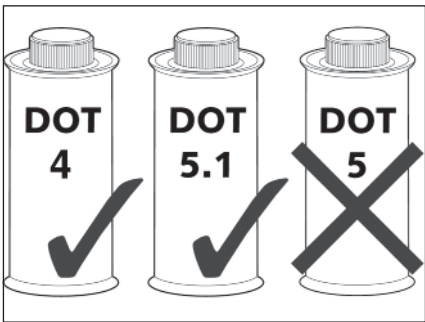

BLEEDING THE FRONT BRAKE

To bleed air from the front brake circuit, proceed as follows:

- Remove the rubber cap **B** from the valve **C**.
- Open the sump cap.
- Insert one end of a transparent tube into a container.
- Pump with the brake lever 2/3 times and keep the lever pressed.
- Unscrew the valve and let the oil drain.
- If air is still visible in the tube repeat above operation until obtaining a continuous outflow of oil without air bubbles.
- Close the valve and release the lever.

NOTE:

during this procedure, continuously top up the brake pump tank to replace the oil that is out flowing.

- Remove the tube.
- Replace the rubber cap.

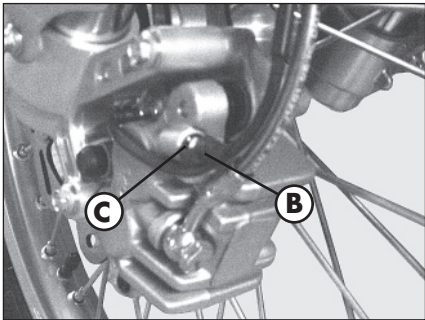

CHECK THE LEVEL OF THE REAR BRAKE FLUID

Check the level of the brake fluid through sight **D**. The level of the fluid should never fall below the mark in the sight.

RESTORING THE LEVEL OF THE REAR BRAKE FLUID

To restore the level of the brake fluid, unscrew cap **3** and pour in brake fluid (BARDAHL BRAKE FLUID DOT 4) until the level reaches the mark in sight **D**.

WARNING

We recommend using DOT 4 brake fluid. Should this fluid be unavailable, use DOT 5.1 fluid instead. Do not on any account use DOT 5 brake fluid. This is a purple fluid with a base of silicone oil which requires special seals and tubes.

WARNING

The brake fluid is extremely corrosive. Take care not to spill it on the paintwork.

BLEEDING THE REAR BRAKE

To bleed air from the rear brake circuit, proceed as follows:

- Remove the rubber cap **E** from the valve **F**.
- Open the sump cap.
- Insert one end of a transparent tube into a container.
- Pump with the brake lever 2/3 times and keep the lever pressed.
- Unscrew the valve and let the oil drain.
- If air is still visible in the tube repeat above operation until obtaining a continuous outflow of oil within no air bubbles.
- Close the valve and release the lever.

NOTE:

during this procedure, continuously top up the brake pump tank to replace the oil that is out flowing.

- Remove the tube.
- Replace the rubber cap.

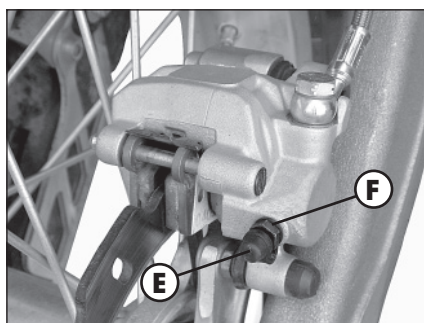
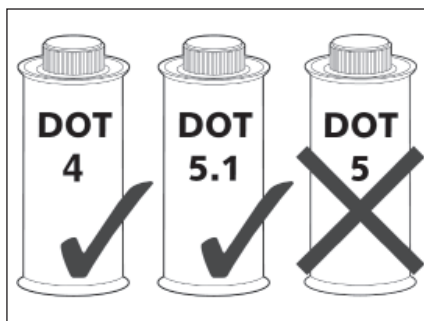
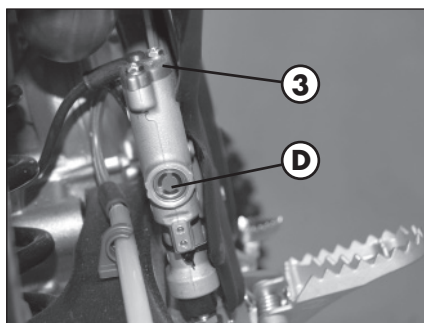

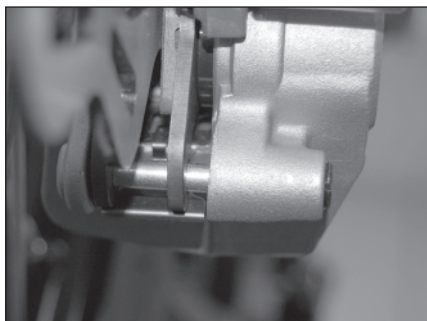

FRONT BRAKE LINING CONTROL

In order to verify the wear condition of front brake is enough to view the plincer from the bottom, where is possible to glimpse the brake lining tails which will have to show a brake of 2 mm in thickness. If the stratum is lesser let's start replacing them.

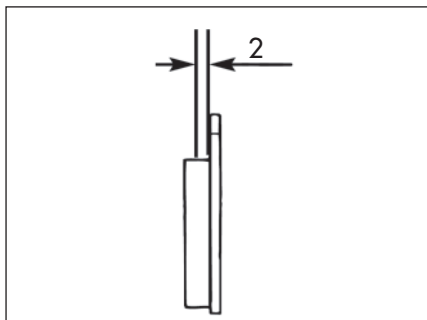

Note

Perform the check according to the times shown in the table on page 55.

WARNING

Failure to promptly replace the brake pads can result in a considerable reduction of the braking action and in damage to the brake disc.



REAR BRAKE LINING CONTROL

In order to verify the wear condition of rear brake is enough to view the plincer from the back side, where is possible to glimpse the brake lining tails which will have to show a brake of 2 mm in thickness. If the stratum is lesser let's start replacing them.

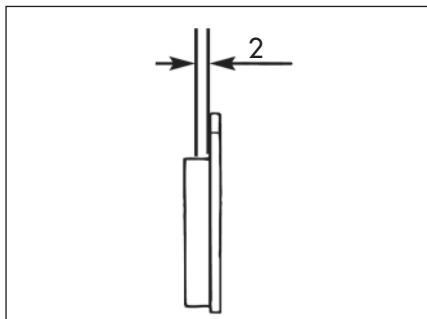

Note

Perform the check according to the times shown in the table on page 55.

WARNING

Failure to promptly replace the brake pads can result in a considerable reduction of the braking action and in damage to the brake disc.

CHECKING THE OIL LEVEL IN THE HYDRAULIC CLUTCH

To check the oil level in the clutch pump, first remove cover **2**.

Remove the two screws **1** and take off cover **2** together with the rubber bellows. With the clutch pump in a horizontal position, the level of the oil should be 5 mm below the upper rim.

If necessary top up with (BARDAHL BRAKE FLUID DOT 5.1) hydraulic oil, which is available from your BETAMOTOR dealer.

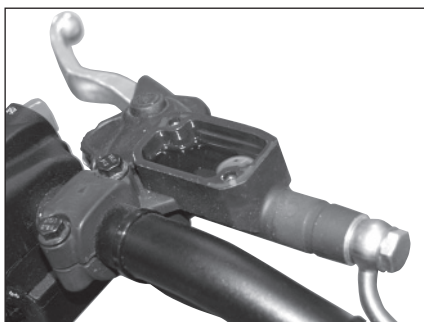
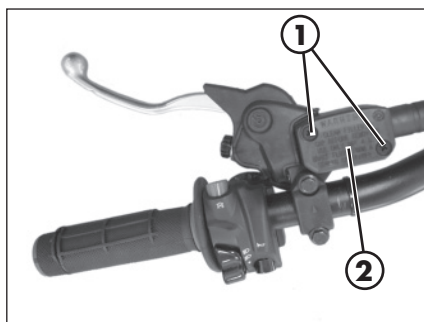

BLEEDING THE HYDRAULIC CLUTCH

To bleed air from the rear clutch pump, proceed as follows:

- Open the sump cap.
- Insert one end of a transparent tube into a container.
- Pump with the clutch lever 2/3 times and keep the lever pressed.
- Unscrew the valve and let the oil drain.
- If air is still visible in the tube repeat above operation until obtaining a continuous outflow of oil within no air bubbles.
- Close the valve and release the lever.

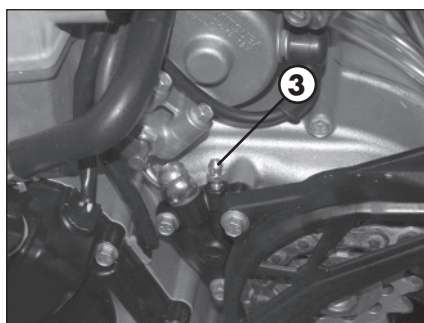

NOTE:

The pump is suitable for bleeding in depression. During this procedure, continuously top up the clutch pump tank to replace the oil that is out flowing.

- Remove the tube.

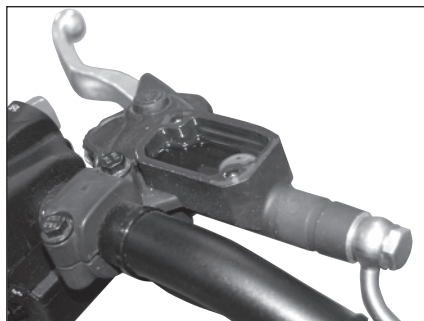

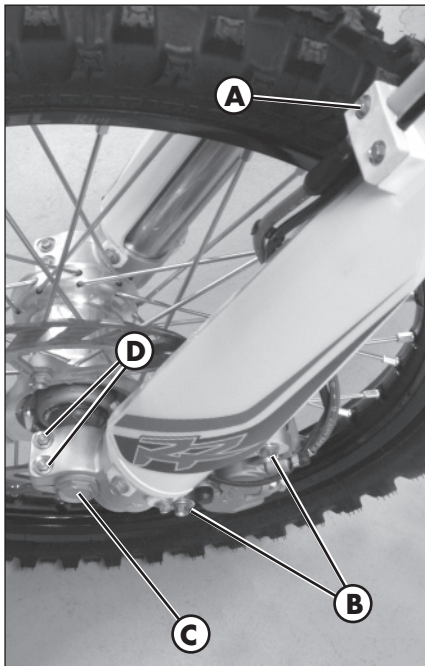

FORK OIL

Right/left-hand rod

The procedure for changing the oil in the forks is provided only for information. We recommend having the operation performed by a BETAMOTOR authorized workshop.

- Rest the motor on a central stand, lift it making sure that it is stable.
- Remove the cable gland U-bolt **A**
- Remove the screws **B** that fix the brake caliper to the left leg and remove the brake caliper.
- Remove cap **C**, loosen the screws **D**, slide the wheel pin out and remove the front wheel.
- Loosen the screws **E** and **F** that block the legs of the of the fork to the plate and slide the fork legs out.
- Place the legs vertically with cap **1** facing upwards. Loosen the upper cap **1**.

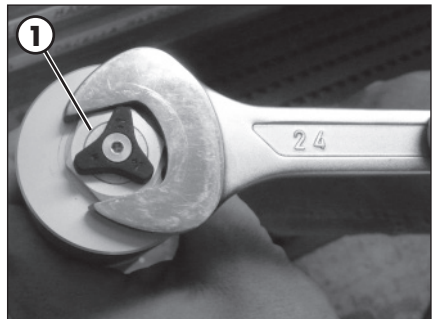

- Loosen the counter-nut **2** and remove cap **1**.

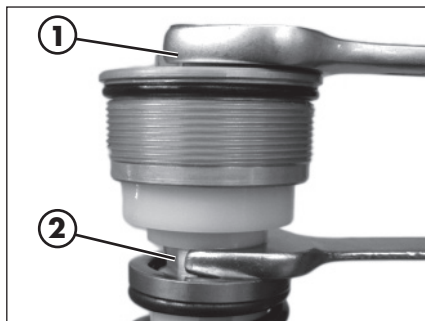

- Extract the spring **3** and overturn the pipe, making the oil escape.

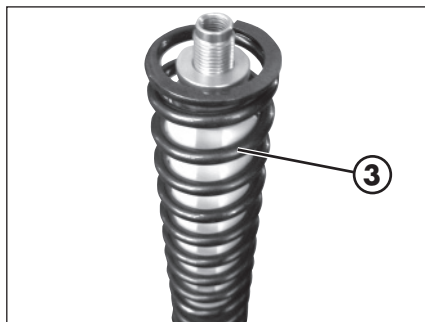

- Move the pumping unit and drain the remaining oil. When the oil has been drained completely, introduce the amount of new oil described in chapter 1.



- Bleed the pumping unit of air, making it rise and fall until complete loading. Introduce the spring and screw the cap **1** until it is completely inserted on the pumping rod. Block the cap to the pumping rod via the counter-nut **2**.

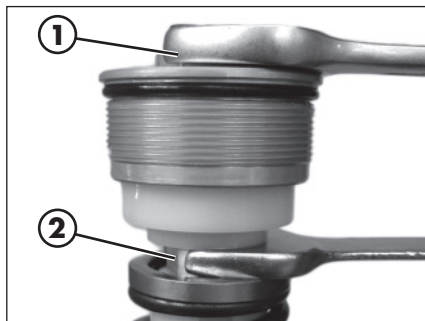



- Tighten the cap to the completely extended leg.

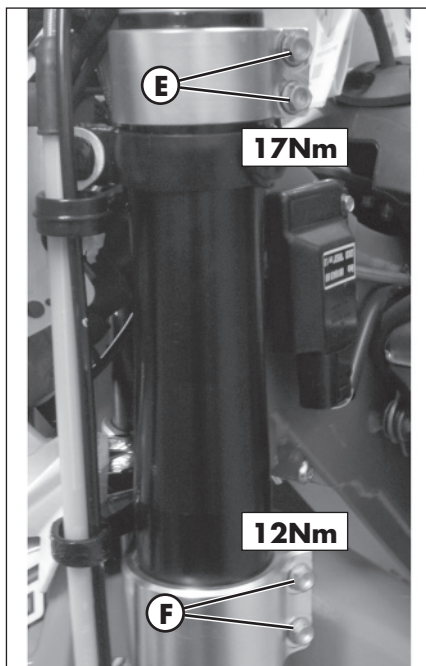

- Insert the legs into the plates. Once the leg has been positioned at the desired extension, tighten screws **E** at 17Nm and **F** at 12Nm, after the screws have been greased.

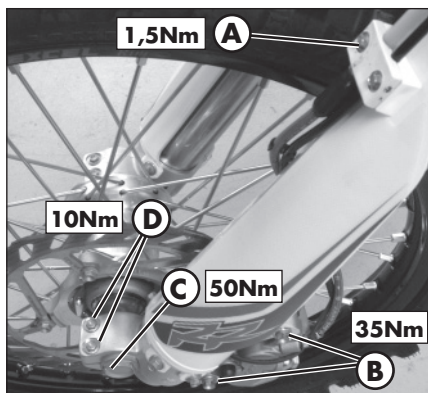

- Apply the wheel complete with spacers, pin and cap **C**, which will be tightened to 50Nm. Tighten the screws **D** to 10Nm. Apply the brake caliper and apply three-dlock of average intensity onto screws **B**. Tighten to 35Nm. Apply the cable gland U-bolt and tighten the screws **A** to 1.5 Nm.

AIR FILTER

A dirty air filter hinders the passage of air, reduces engine power and increases fuel consumption. For these reasons it is essential to clean the air filter on a regular basis.

Follow these steps to gain access to the air filter.

- Pull the cover air filter.
- Release filter fastener **1**.
- Soundproof shell removal
- Pull out air filter **2**.
- Carefully wash the filter with soap (or special detergent) and water.
- Dry the filter.
- Wet the filter with filter oil and then remove the excess oil to prevent it from dripping.

WARNING

To avoid corroding the filter, do not clean it in foam containing petrol or petroleum. Never use the vehicle if the air filter is not in place. The infiltration of dust and dirt can cause damage and considerable wear.

- If necessary clean the inside of the filter box.
- Replace the filter taking special care to ensure the seal of the rubber gasket.
- Attach filter fastener **1**.

WARNING:

After each operation check that no object is left in the filter box.

Clean the filter every time the vehicle is used over rough ground.

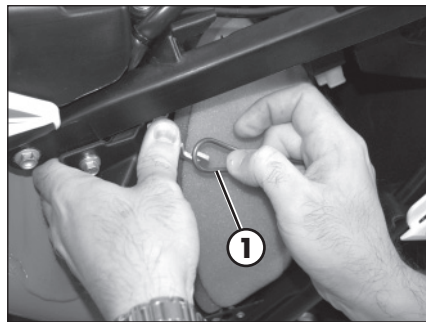
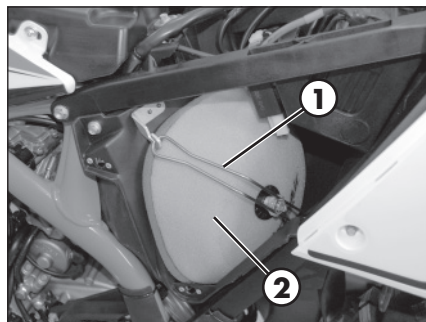
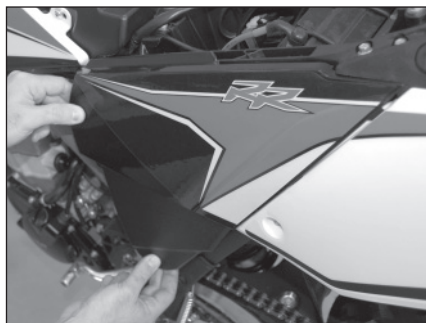

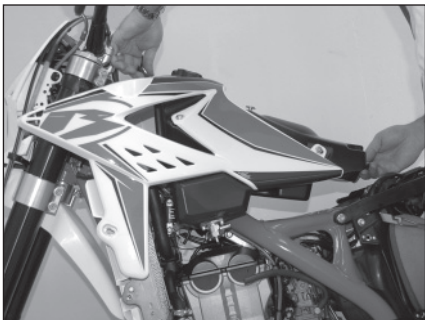
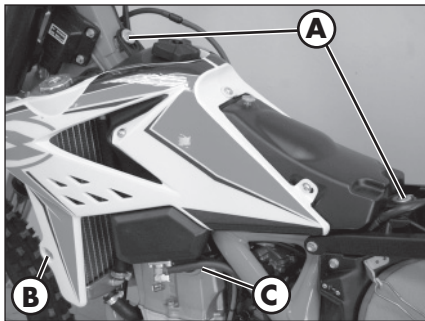

SPARK PLUG

To accede to spark plug, is necessary to take off saddle and the fuel tank.

To remove the fuel tank proceed as follows. Unscrew the two screws **A**, unscrew the screw **B** (both side). Close the fuel tap (OFF position) and disconnect the pipe fuel **C** from the fuel tap.

Lift the fuel tank.

Keeping the spark plug in good condition makes for reduced consumption and optimum engine performance.

It is advisable to remove the spark plug when the engine is hot (and naturally off) because the carbon formation and the colour of the insulator provide important information on carburetion, lubrication, and the general condition of the engine.

Note

Black spark plug = mixture is rich

Light brown spark plug = mixture is correct

White spark plug = mixture is lean

This operation must be performed with the utmost care to avoid severe hand burns. Always wear protective gloves.

To carry out the check, simply remove the current cap and then unscrew the spark plug using the spanner provided. Carefully clean the electrodes using a wire brush. Blow the spark plug with compressed air to prevent any residues from getting into the engine.

Measure the spark gap with a thickness gauge. The gap should be $0.8 \div 0.9$ mm. If the gap is not as specified, restore the proper gap by bending the earth electrode.

Check that the insulator is not cracked and that the electrodes are not corroded, in which case the spark plug should be immediately replaced.

Conduct the check by referring to the table on page 55.

Lubricate the spark plug thread, and then (when the engine is cold) screw in the spark plug by hand to its abutting end. Finally tighten the spark plug with the spanner.

Note:

- Always use NGK LKAR 8A-9 spark plugs.

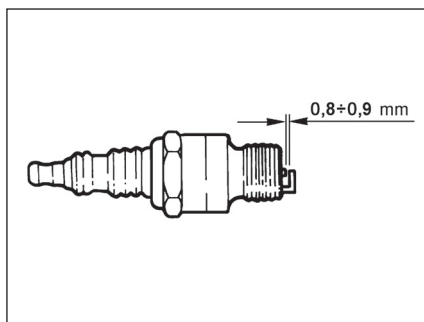

3

CARBURETTOR WEAR GUIDELINES

The throttle valve, the needle valve and the needle jet are subject to heavy wear due to engine vibrations.

This can result in carburettor malfunctions (e.g. mixture enrichment).

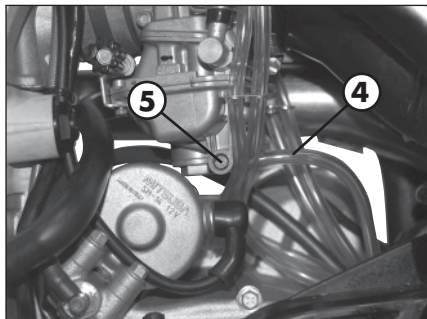

DRAINING THE CARBURETTOR FLOAT CHAMBER

The carburettor float chamber can be drained by following the procedure described below while the engine is cold. Close the fuel cock and place tube **4** in a container to gather the fuel that flows out. Open drain screw **5** and drain the fuel. Close the drain screw, open the fuel cock and check the seal of the system.

WARNING

Fuel is flammable and toxic and must be handled with great care. Never work on the fuel system near heat sources or open flames. Always allow the engine to cool down before working on the fuel system. Wipe off any excess fuel with a rag. Materials soaked in fuel are also flammable. In case of ingestion or contact with sensitive parts of the body immediately seek medical attention. Fuel is to be disposed of as prescribed by law.

CHECKING THE FLOAT LEVEL (float height)

Remove the carburettor and the float chamber. Tilt the carburettor so that the float touches the float needle valve without pressing it too hard.

In this position the float edge should be parallel with the float chamber sealing surface (see figure).

If the float height does not correspond to the nominal value, check the float needle valve and if necessary replace it.

If the needle valve is in working order, adjust the float height by bending float lever **3**.

Fit the float chamber, install the carburettor and adjust the idle speed.

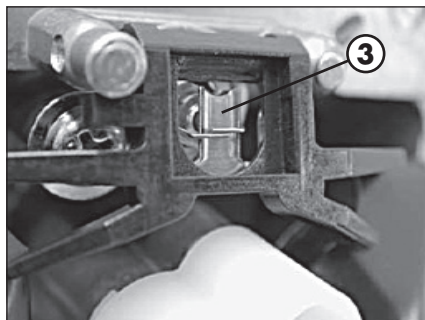
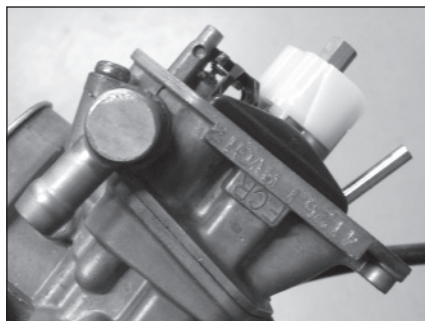

COOLANT

The level of the coolant must be checked when the engine is cold. Use the following procedure:

- Unscrew cap **A** and visually check the level of the liquid. When the engine is cold, the radiator fins should be immersed in the liquid for about 10 mm.
- Top up if the coolant does not cover the radiator fins (see chart on page 31).

The capacity of the circuit is shown in the table on page 22.

WARNING

To avoid scalds, never unscrew the radiator filler cap when the engine is hot.

The life of the drive chain largely depends on its maintenance. Chains without X-rings must be periodically cleaned in petroleum and then immersed in hot chain oil or treated with a chain spray.

X-ring chains require very little maintenance. The best way to clean them is rinsing them generously with water. Never use brushes or solvents to clean an X-ring chain. Once the chain has dried, you can use a chain spray specially designed for X-ring chains.

Take special care in preventing the lubricant from coming into contact with the rear tyre or brake disc, otherwise the tyre grip and the action of the brake would be greatly reduced, making it very difficult to control the vehicle.

DRIVE CHAIN WEAR

To check the wear of the drive chain use the procedure described below.

Shift into neutral, pull up the upper stretch of the chain with a force of 10 - 15 kg (see figure). Measure the length of 18 links on the lower stretch of the chain. If the length is ≥ 272 mm, replace the chain. Chains do not always wear evenly. For this reason it is important that the measurement is taken at different points along the chain.

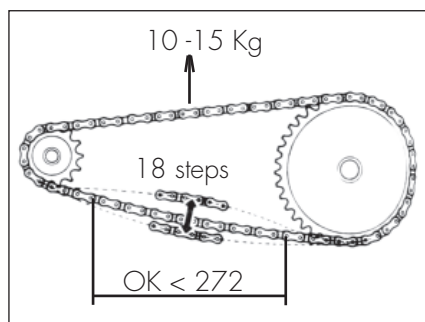

When fitting a new chain, be sure to replace the chainring and sprocket as well. New chains wear more quickly if fitted on old and worn sprockets. After replacing the chain, adjust its tension as described on page 64.



CHARGING THE BATTERY

Remove the battery and check its charge. Using an open-circuit multimeter (10-12 hours after the activation), check that the voltage is greater than 12.6 V. If it is lower, it is advisable to recharge the battery.

Based on the type of charger available, charge the battery using either of the following procedures:

- Constant voltage (14.4-15 V) - Charge the battery for about 12 hours. Check the voltage 10-12 hours after the end of recharge as described above.
- Constant current: Charge battery at 0.5-0.8 A until the voltage between the terminals stabilizes at ~14.5 V.

WARNING

The battery is sealed. When recharging it, do not remove the seal nor add any liquid.

WARNING

When recharging, first connect the battery to the battery charger and then turn on the charger.

If the battery is charged in a closed room, take care to ensure proper ventilation as during the charge the battery produces explosive gases.

CLEANING AND CHECKING THE VEHICLE

Use water jet to soften the dirt and mud accumulated on the paintwork, then remove them with a soft bodywork sponge soaked in water and shampoo (2-4 percent shampoo in water). Subsequently rinse well with water, and dry with air and cloth or suede leather. For the outside of the engine use a brush soaked in petroleum and clean rags. Petroleum damages the paintwork. Always wash the vehicle before waxing it with silicon waxes.

Important:

When cleaning using a high-pressure water jet cleaner, avoid aiming the jet to the digital instrument panel.



Detergents pollute water. Always wash the vehicle in areas equipped for collection and purification of the washing liquids.



Never wash the vehicle in the sun, particularly during the summer when the bodywork is hot. The shampoo would dry before being rinsed off and cause damage to the paintwork. Do not clean the plastic surfaces with cloths soaked in petrol or naphtha as they would lose their shine and mechanical properties.

CHECKS AFTER CLEANING

After cleaning the motorcycle, it is advisable to:

- Clean the air filter (refer to the procedure described on page 47).
- Empty the fuel container by loosening the fuel emptying screw in order (as described on page 50) to check for the presence of water.
- Add grease to the chain.

SCHEDULED MAINTENANCE VEHICLE

UNIT	INTERVENTION	1 st coupon after 3h or 20l (fuel)	Every 15h or 100l (fuel)	Every 30h or 200l (fuel)	Every 60h or 400l (fuel)
ENGINE	Engine oil	S	-	S	-
	Paper filter oil	S	-	S	-
	Wire netting filter oil	P	-	P	-
	Gear and clutch oil	S	-	S	-
	Spark plug	I	-	-	S
	Valve clearance	I	-	I	-
	Engine clamping screws	I	I	-	-
	Kick start and gearchange lever screws	I	I	-	-
	Spark plug cap	P	P	-	-
CARBURETOR	Tightness	I	I	-	-
	Idling setting	I	I	-	-
	Fuel pipe	I	I	-	-
	Breather pipe	I	I	-	-
ASSEMBLING GROUPS	Coolant system tightness and coolant level	I	I	-	-
	Exhaust manifold tightness	I	I	-	-
	Drives sliding and regulation	I	I	-	-
	Liquid level clutch pump	I	I	-	-
	Airbox and air filter	P	P	-	-
	Chain, plate wheel and pinion	I	I	-	-
BRAKE	Liquid level, pads thickness	I	I	-	-
	Disc thickness	I	I	-	-
	Pipe tightness	I	I	-	-
	Idle travel levers and drives sliding	I	I	-	-
CYCLING	Shock absorber and telescopic fork	I	I	-	-
	Fork cover	P	P	-	-
	Bearings of steering	I	I	-	-
	Nuts and bolts	T	T	-	-
WHEELS	Spokes	I	I	-	-
	Tyres	I	I	-	-
	Bearings clearance	I	I	-	-

SCHEDULED MAINTENANCE ENGINE

The required engine maintenance is strongly depending on the level of use and on the accordingly done periodic checks and service.

The below mentioned maintenance intervals are for standard competition use, subject to the condition that the engine was never running under extraordinary conditions and the periodic service was done accurately.

	30h 200l	60h 400l	90h 600l	120h 600l	150h 800l	180h 1200l
Clutch disc wear	I	I	S	I	I	S
Clutch springs length	I	I	S	I	I	S
Gearbox bearing (crankcase side)	-	-	S	-	-	S
Clutch hub / basket wear	I	I	I	I	I	I
Cylinder wear	-	-	I	-	-	I
Piston and segments	-	-	S	-	-	S
Camshaft wear	-	-	I	-	-	I
Valve spring	-	-	I	-	-	S
Valves 400 - 450 - 498	-	-	I	-	-	I
Valves 350	-	-	I	-	-	S
Valve guide wear	-	-	I	-	-	I
Connecting rod	-	-	S	-	-	S
Countershaft bearings	-	-	S	-	-	S
Crankshaft bearings	-	-	S	-	-	S
Wear gearbox / shifting	-	-	I	-	-	I
Pressure control valve spring length	-	-	I	-	-	I
Water pump seals	-	-	S	-	-	S
Oil pump control gears	-	-	I	-	-	S

I = Inspect and if necessary replace

S = Replace / renew

Note:

For any service requirements, please contact Betamotor's Authorized Service Network.

PROLONGED INACTIVITY

A few simple operations should be performed to keep the vehicle in good condition whenever it is to remain inactive for a long period (e.g. during the winter):

- Thoroughly clean the vehicle.
- Reduce the tyre pressures by approximately 30 percent, and if possible raise the tyres off the ground.
- Remove the spark plug and pour a few drops of engine oil into the spark plug hole. Make the engine turn a few times by operating the kick-start (where available) and then replace the spark plug.
- Cover the unpainted parts, excepting the brakes and the rubber parts, with a film of oil or spray silicone.
- Remove the battery and keep it in a dry place. Charge the battery every 15 days.
- Protect the vehicle with a dust cover.
- Drain the carburetor float chamber by loosening screw **A**. The fuel drained from the chamber through a suitable pipe must be collected in a container and poured into the fuel tank. Do not dispose of the fuel in the environment.
- Retighten the screw.

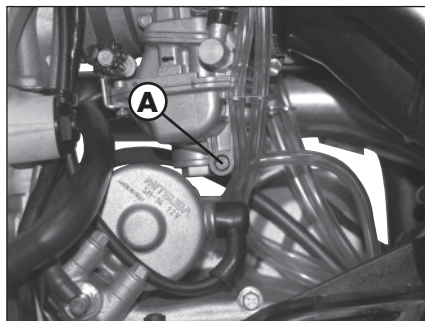

AFTER PROLONGED INACTIVITY

- Reinstall the battery.
- Restore the tyre inflating pressures.
- Check the tightening of all the screws having an important mechanical function.

Note:

Periodically check the tightening of the screws.

- Start the vehicle for the first time by means of the kick-start.

CONTENTS

CHAPTER 4 ADJUSTMENTS

Brake adjustment: front lever and brake pedal

Adjusting the home position of the clutch lever

Adjusting the handlebars

Adjusting the throttle control cable

Checking and adjusting the steering play

Adjusting the Suspensions: telescopic fork and shock absorber

Tensioning the chain

Idling setting

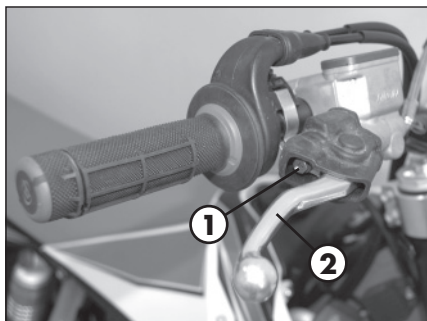

ADJUSTING THE HOME POSITION OF THE FRONT BRAKE LEVER

The home position of brake lever **2** can be adjusted by means of screw **1**.

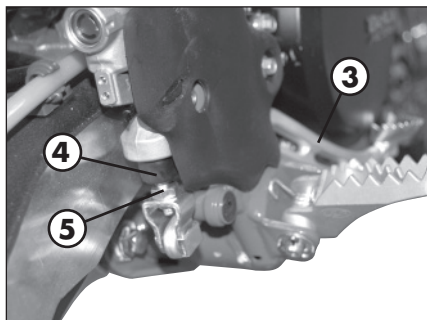

ADJUSTING THE HOME POSITION OF THE BRAKE PEDAL

The home position of brake pedal **3** can be altered by turning adjusting screw **5** after loosening the counternut located under dust cap **4**. Loosen the counternut and turn the adjusting screw until the desired height is obtained. Retighten the counternut after completing the operation.

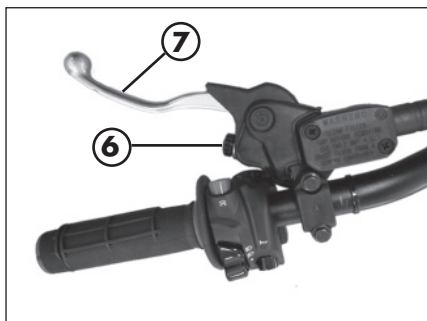

ADJUSTING THE HOME POSITION OF THE CLUTCH LEVER

The adjustment screw **6** allows adjustment of the distance of lever **7** from the knob. The empty run is recovered automatically.

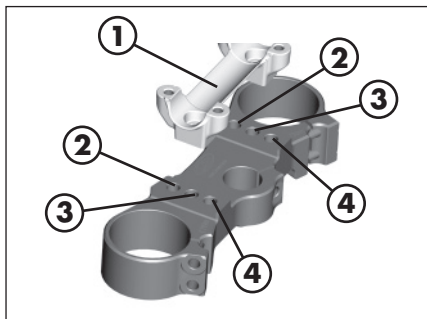

ADJUSTING THE HANDLEBARS

The lower bracket **1** can be mounted on the holes nr. **2**, **3** or **4** respectively, while the handlebar can be rotated by 180° in order to meet the driver's specific driving needs.

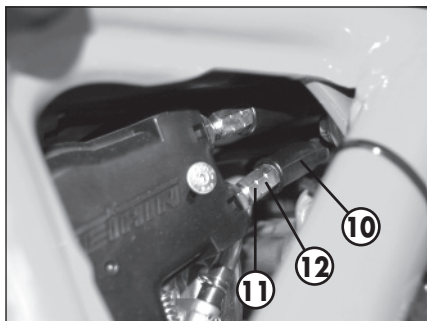

ADJUSTING THE THROTTLE CONTROL CABLE

The throttle control cable should always have a 3-5 mm play. In addition, the idle speed should not change when the handlebars are fully rotated to the left or right. Push back protective cap **10**. Loosen counternut **11** and turn adjusting screw **12**. Turning the screw anticlockwise decreases the idle travel; turning it clockwise increases it. Tighten the counternut and check that the throttle twist grip turns smoothly.



CHECKING AND ADJUSTING THE STEERING PLAY

Periodically check the play of the steering head tube by moving the forks backwards and forwards as shown in the figure. If any play is felt, carry out the adjustment by following these steps:

- Loosen the four screws **13** and screw **14**.
- Recover the play by intervening on screw **15**.
- Tighten the screws **13** to 17Nm.
- Tighten the screw **14** to 20 Nm.

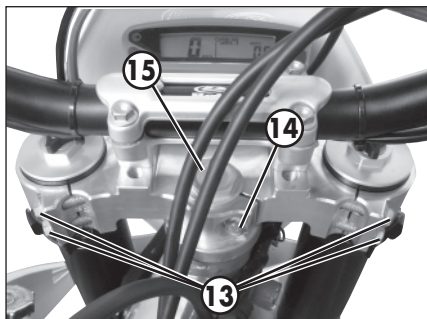

Note:

Proper adjustment must leave no play and cause no stiffness, and allow the steering to rotate smoothly. Check the fitting direction of the clevises as it can alter the geometry of the handlebar.

TELESCOPIC FORK

ADJUSTING THE REBOUND DAMPER

The hydraulic rebound damper determines the behaviour of the telescopic fork during extension and can be adjusted by means of screw **A**. Turning the screw clockwise (towards the + sign) increases the action of the rebound damper; turning it anticlockwise (towards the - sign) decreases the action of the rebound damper.



Standard adjustment **RR 4t**:
12 clicks from the completely closed position

ADJUSTING THE COMPRESSION DAMPER

The hydraulic compression damper determines the behaviour of the telescopic fork during compression and can be adjusted by means of screw **B** located at the lower end of the fork legs. Turning the screw clockwise increases the action of the compression damper; turning it anticlockwise decreases the action of the compression damper.

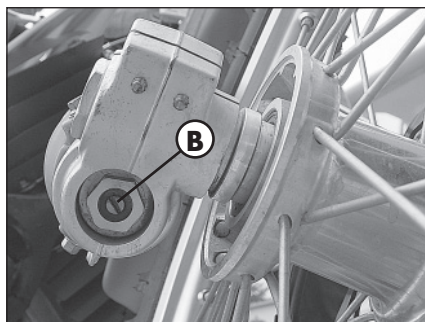

Standard adjustment **RR 4t**:
12 clicks from the completely closed position

SHOCK ABSORBER

ADJUSTING THE HYDRAULIC COMPRESSION DAMPER (high and low speeds)

The shock absorber can be adjusted for both high and low speeds. The terms 'high' and 'low' refer to the compression speed of the shock absorber, not to the speed of the vehicle. The low-speed adjustment affects the behaviour of the shock absorber during low-speed compression; conversely the high-speed adjustment affects its behaviour during high-speed compression.

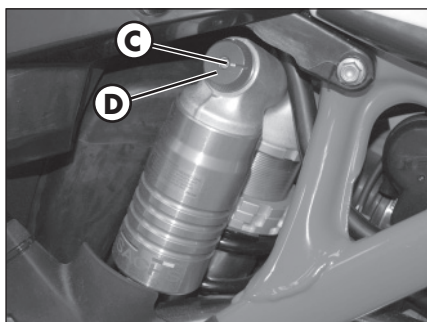

Low-speed adjustment

- Using a screwdriver, loosen screw **C** by turning it clockwise to increase the hydraulic compression damper.

Standard adjustment **RR 4t**:

22 clicks from fully closed

High-speed adjustment:

- Turn knob **D** anticlockwise to decrease the hydraulic compression damper.

Standard adjustment **RR 4t**:

20 clicks from fully closed

WARNING

Starting from the standard position, turn the knob anticlockwise (with a closing action), the center screw will have an integral movement, then will rotate with the knob.

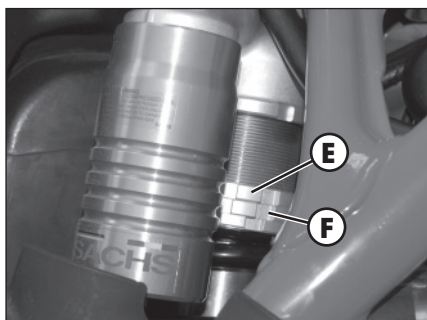

ADJUSTING THE SPRING PRELOAD

To adjust the spring preload, use the procedure described below. Loosen counter-ring **E**, Rotate ring **F** clockwise to increase the spring preload (and consequently the shock absorber preload) or anticlockwise to decrease it. After obtaining the desired preload, turn counter-ring **E** until it stops against adjusting ring **F**.

Spring length in running position: 48 mm

4

ADJUSTING THE HYDRAULIC REBOUND DAMPER

Turn screw **G** to adjust the hydraulic rebound damper.

Turning the screw anticlockwise (out) decreases the damping effect.

Standard adjustment **RR 4t**:

20 clicks from the completely closed position

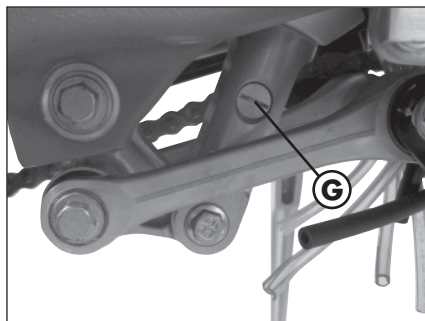

TENSIONING THE CHAIN

To ensure the drive chain a longer life, it is advisable to periodically check its tension. Always maintain the chain clean and lubricated.

If the chain play exceeds $30 \div 35$ mm, tension the chain by following these steps.

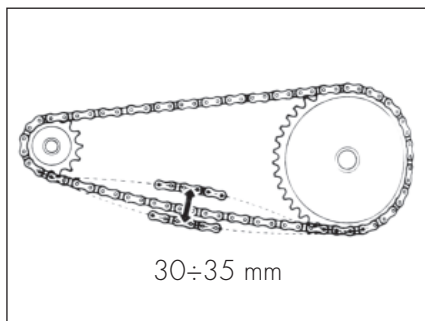

- Loosen wheel spindle nut **1**.
- Loosen conternuts **A** on either side of the fork
- Turn adjusting screws **B** on either side until the desired chain tension is obtained.
- Tighten conternuts **A** on either side of the fork
- Tighten nut **1**.

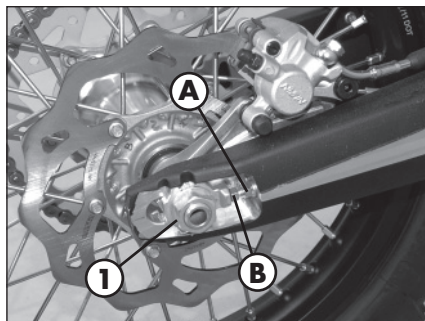
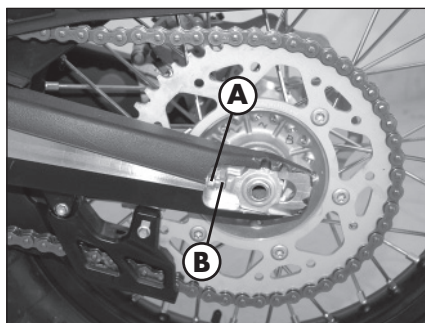

ADJUSTING THE IDLE SPEED

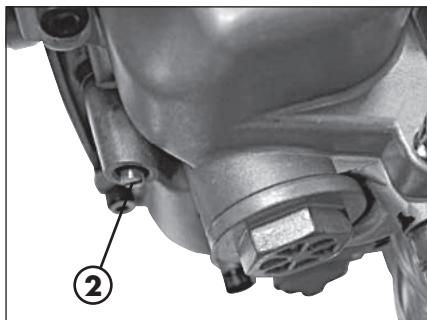
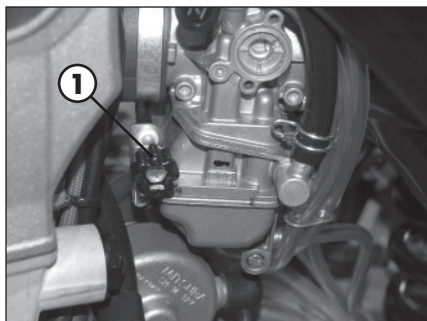

Engine starting is strongly affected by the idle speed adjustment. In other words, an engine whose slow running is properly adjusted is easier to start than an engine with an unsuitably tuned up engine.

The idle speed is adjusted by means of adjusting knob **1** and mixture adjusting screw **2**. The adjusting knob regulates the base position of the throttle valve. By turning the knob clockwise increases the rotation speed and counter-clockwise to lower it. The mixture control screw adjusts the amount of the mixed fuel with air for the idle speed. Rotating the screw clockwise decreases the quantity of fuel (lean mixture); rotating in anticlockwise increases the quantity of fuel (rich mixture).

To properly adjust the idle speed, follow these steps:

- Turn in mixture adjusting screw **2** until it stops, then turn it until you obtain the basic adjustment recommended by BETAMOTOR (see engine specifications on page 23).
- Warm up the engine.
- Turn adjusting knob **1** to obtain the standard idle speed (1500-1600 rpm).
- Slowly turn mixture adjusting screw **2** clockwise until the idle speed begins to lower. Remember this position, then slowly turn the mixture adjusting screw anticlockwise until the engine speed lowers again. Determine the point between the two positions where the highest idle speed is obtained. Should the engine speed increase considerably, decrease the engine speed to the standard level and repeat the above procedure. If you make a markedly sporting use of your vehicle, which increases the heating of the engine, choose a leaner mixture by turning the adjusting screw approximately 1/4 of a turn clockwise from the ideal setting.

Refer to the specifications carburetor or refer website www.betamotor.com.

4

NOTE

Failure to successfully complete the above procedure can be the result of an improperly sized idling jet.

a) If the mixture adjusting screw is turned until it stops and no changes in the idle speed are observed, a smaller idling jet is required.

b) If the engine stalls when the adjusting screw is still two turns open, a larger idling jet is needed.

Naturally, after replacing the jet the adjusting procedure will have to be restarted from the beginning.

- Turn the adjusting knob until you obtain the desired idle speed.
- The idle speed will have to be adjusted again in case of marked changes in the outside temperature and riding altitude.

CONTENTS

CHAPTER 5 REPLACEMENTS

Replacing the brake pads: front and rear

Replacing the headlight bulbs

Replacing the rear optic batch

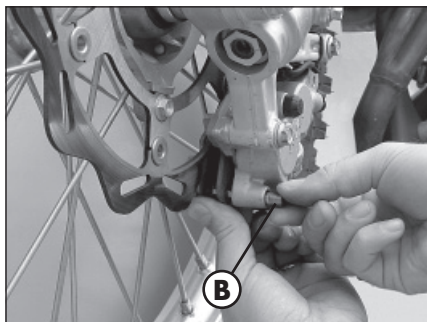
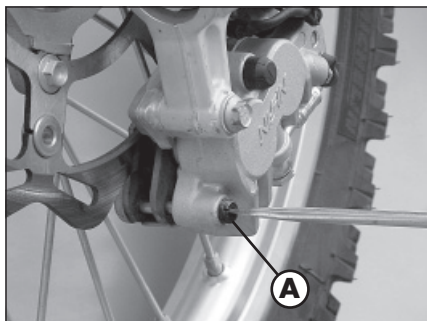

REPLACING THE BRAKE PADS

The procedure for replacing the brake pads is provided only for information. We recommend having the operation performed by a BETAMOTOR authorized workshop.

FRONT

Follow these steps to replace the pads:

- Push the brake caliper towards the disc so that the pistons reach their home positions.
- Unscrew dowel **A**.
- Pull out pin **B**, while supporting the two pads as shown in the figure.
- Remove the brake pads taking care not to drop the leaf spring located under the pads.
- To reassemble, follow the reverse procedure. When fitting the pads, ensure that the leaf spring is properly in place.

WARNING

The brake disc must always be kept free from oil and grease. An oily or greasy disc strongly reduces the braking action.

After work has been carried out on the braking system, pull the brake lever to bring the pads into contact with the disc. This will allow the correct pressure point to be restored, thus ensuring proper operation of the braking system.

REAR

Follow these steps to replace the pads:

- Push the brake caliper towards the disc so that the pistons reach their home positions.
- Unscrew dowel **A**.
- Pull out pin **B**, while supporting the two pads as shown in the figure.
- Remove the brake pads taking care not to drop the leaf spring located above the two pads.
- To reassemble, follow the reverse procedure. When fitting the pads, ensure that the leaf spring is properly in place.

WARNING

The brake disc must always be kept free from oil and grease. An oily or greasy disc strongly reduces the braking action. After work has been carried out on the braking system, pull the brake lever to bring the pads into contact with the disc. This will allow the correct pressure point to be restored, thus ensuring proper operation of the braking system.

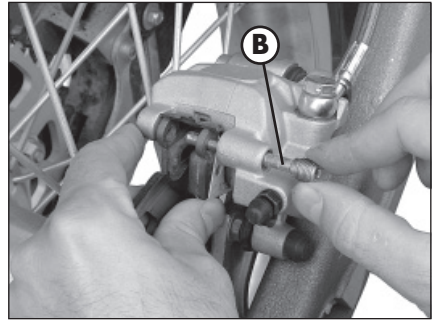
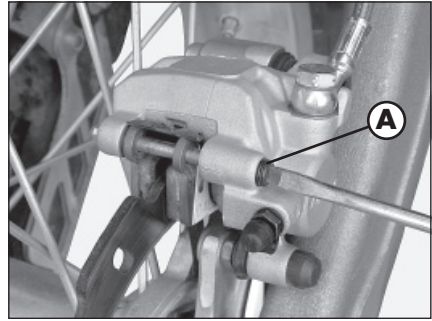

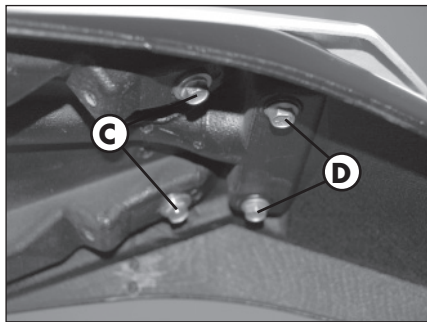
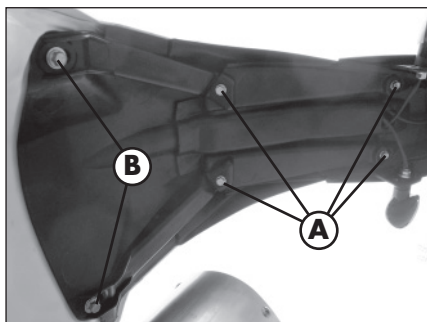
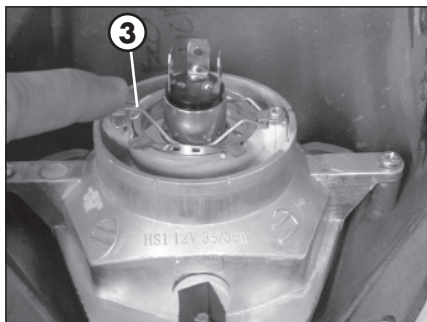
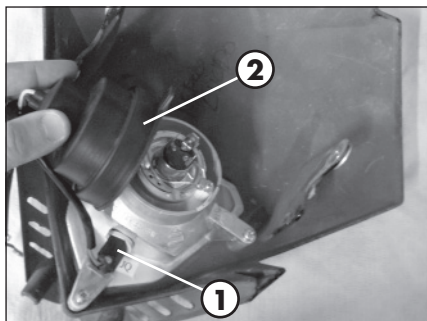

REPLACING THE HEADLIGHT BULBS

Release both spring washers and move forward the lamp holder front cowl.

Carefully remove the headlight bulb **1** together with lamp holder. To replace the high beam / low beam, lift the rubber cover **2**, release connector, push on the spring **3** and remove the lamp holder and replace the light bulb with a new one. Be careful not to touch the bulb so as not to compromise its efficiency.

To refit, follow the procedure above but in reverse order.

Fasten the lamp holder front cowl to the supporting pins and fix it with the two elastics.

REPLACING THE REAR OPTIC BATCH

The rear optical batch led type.
To replacing the rear optical batch, remove the rear fender proceed as follows.

Remove the saddle and unscrew the four screws **A** and disconnect the electrical connector.

Unscrew the four screws **B** and **C**, and the two screws **D**. The **D** screws connect the optic batch to the racing number plate holder.

Unscrew the two **E** screws and the four **F** screws. Take off the rear fender.

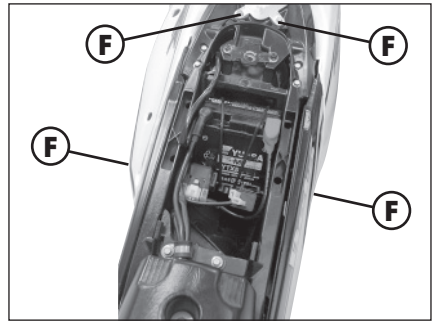
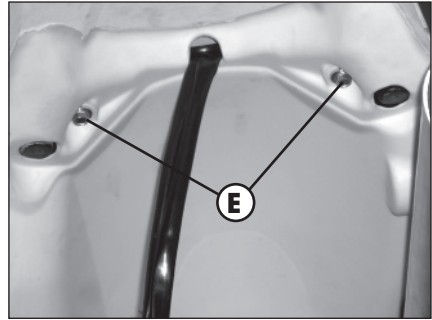

Disconnect the connector **A** and unthread the cable.

To reassemble the optical batch, insert before the connector in the hole **B**, and then put the cable as it shown in the picture.

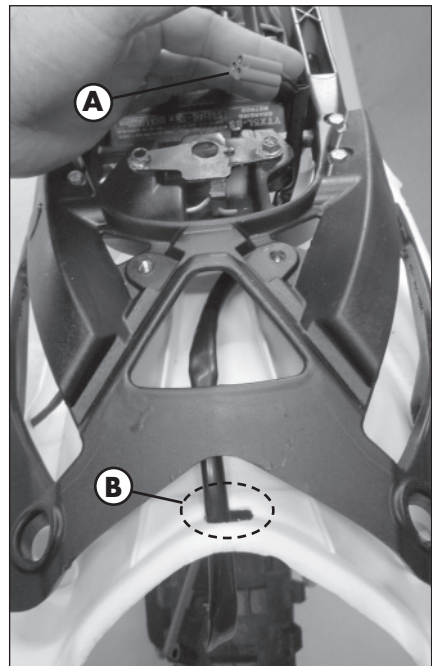

CONTENTS

CHAPTER 6 TROUBLESHOOTING

INDEX

PROBLEM	CAUSE	REMEDY
Engine does not start	-Fuel system clogged (fuel lines, fuel tank, fuel cock).	Clean the system.
	-Air filter dirty.	Proceed as described on page 47.
	-No current supplied to spark plug.	Clean or replace the spark plug. If the problem persists, contact a BETAMOTOR dealer.
	-Engine flooded.	Operate the start-up pedal 5-10 times or the electrical starter pushbutton 2 times every 5 seconds. If the vehicle does not start, remove and dry the spark plug.
Engine misfires	-Spark gap wrongly adjusted.	Restore the spark gap.
	-Spark plug dirty.	Clean or replace the spark plug.
Engine knocks	-Spark advance excessive.	Check CDI: contact a BETAMOTOR dealer.
	-Carbon formation in cylinder or on spark plug.	Contact a BETAMOTOR dealer.
Engine overheats and loses power	-Silencer partly clogged.	Contact a BETAMOTOR dealer.
	-Exhaust port clogged.	Contact a BETAMOTOR dealer.
	-Ignition delayed.	Check CDI: contact a BETAMOTOR dealer.
Front braking poor	-Brake pads worn.	Follow the procedure described on page 68
	-Air or humidity in the hydraulic circuit.	Follow the procedure described on page 40
Rear braking poor	-Brake pads worn.	Follow the procedure described on page 69
	-Air or humidity in the hydraulic circuit.	Follow the procedure described on page 41

Air filter	47
Battery: load	53
Bleeding clutch	43
Bleeding the brakes: front and rear	40
Brakes adjustment: front and rear.....	60
Carburetor	50
Checking and adjusting the steering play	61
Checks to be performed before each ride	30
Cleaning and checking the vehicle	54
Clutch adjustment	60
Clutch oil: check the level	43
Controls.....	13
Coolant.....	51
Delivery.....	8
Drive chain: maintenance and wear	52
Electrical devices.....	27
Engine oil: check.....	36
Engine oil: filters replacement and extraction.....	37
Fork oil: right/left rod	44
Front and rear brake: check pads.....	42
Front and rear brake: check the level.....	40
Gas clearance, adjustment.....	61
Gearbox/clutch oil replacement.....	39
Handlebars, adjustment	60
Idle speed, adjustment.....	65
Load	10
Lubricants.....	31
Oil circuit	36
Refuelling	33
Replacing the brake pads: front and rear	68
Replacing the bulbs	70
Running-in	31

Scheduled maintenance.....	55
Spark plug	48
Specifications	21
Starting	32
Steering lock	11
Suspensions: telescopic fork and shock absorber	62 ÷ 64
Tensioning the chain.....	64
Troubleshooting	74
Tyres	10
Vehicle identification data	8
Vehicle: familiarizing with.....	12
Vehicle: prolonged inactivity	57
Wiring diagram RR 4t	25