

CATALOGO PARTI DI RICAMBIO
CATALOGUE OF SPARE PARTS
CATALOGUE PIECES DE RECHANGE
ERSATZTEILKATALOG
CATALOGO DE PIEZAS DE REPUESTO

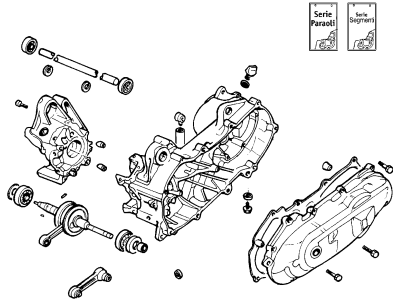

TAV.1 Carter - Albero motore - Crankcase - Crankshaft - Carter - Vilebrequin - Kurbelwellengehäuse - Kurbelwelle - Carter - Cigüeñal



TAV.2 Gruppo cilindro-pistone-spinotto - Cylinder-piston-wrist pin assy. - Groupe cylindre-piston-axe - Zylinder/Kolben kpl - Grupo cilindro-pistón-eje

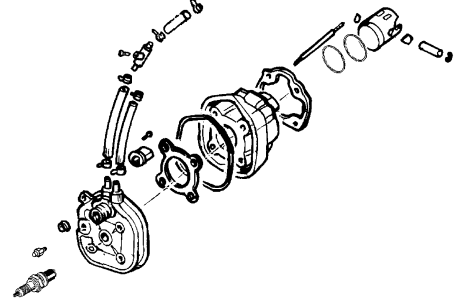

TAV.3 Puleggia motrice - Puleggia condotta - Driving pulley - Driven pulley - Variateur - Poulie conduite - Antriebsriemenscheibe - Riemenscheibe - Polea motriz - Polea conducida

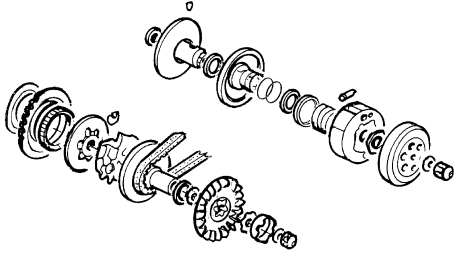

TAV.4 Asse ruota posteriore - Rear wheel axle - Axe roue AR. - Hinterradachse - Eje rueda trasera

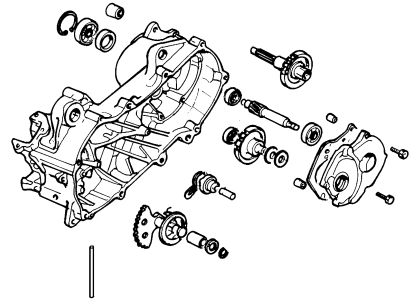

TAV.5 Volano magnete - Pompa acqua - Flywh.magn. - Water pump - Volant magnetique - Pompe à eau - Lichtmaschine, kpl. - Wasserpumpe - Volante magn. - Bomba agua

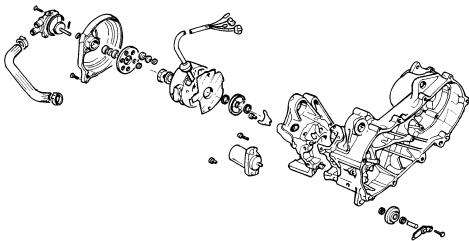

TAV.6 Pompa olio - Carburatore - Oil pump - Carburator - Pompe huile - Carburateur - Ölpumpe - Vergaser - Bomba aceite - Carburador

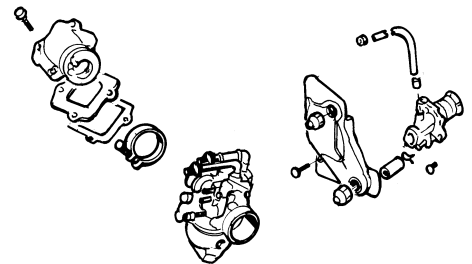

TAV.7 Impianto di raffreddamento - Installation de refroidissement - Installation de refroidissement - Kühlsystem - Instalación de enfriamiento

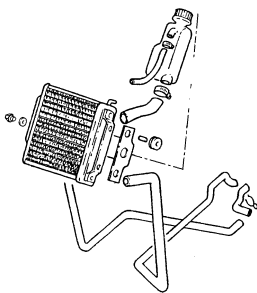

TAV.8 Filtro aria - Air filter - Filtre à air - Luftfilter - Filtro de aire



TAV.9 Marmitta - Silencer - Silencieux - Auspufftopf - Silenciador

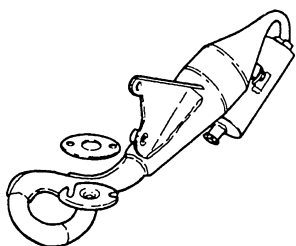

TAV.10 Serbatoio carburante - Serbatoio olio - Fuel tank - Oil tank - Reservoir carburant - Reservoir d'huile - Benzintank - Öltank - Tanque carburante - Deposito aceite

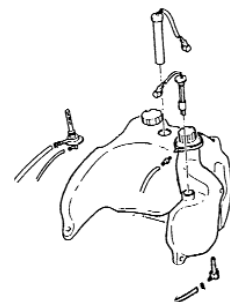

TAV.11 Dispositivi elettrici - Electrical devices - Dispositifs électriques - Elektrische Ausrüstung
- Dispositivos electricos

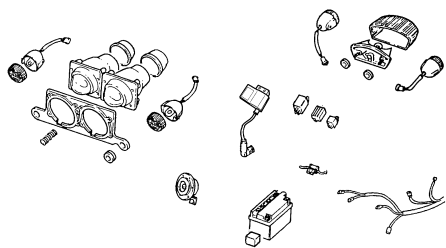

TAV.12 Sospensioni - Suspensions - Suspensions - Federungen - Suspensióes

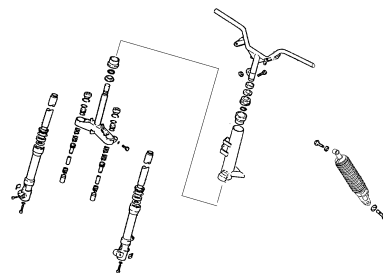

TAV.13 Ruota anteriore-Ruota posteriore - Front wheel-Rear wheel - Roue AV.-Roue AR. -
Vorderrad-Hinterrad - Rueda delantera-Rueda trasera

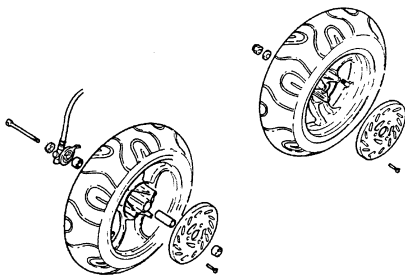

TAV.14 Trasmissioni - Transmissions - Transmissions - Seilzüge - Transmisiones

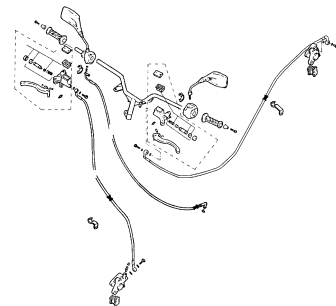

TAV.15 Telaio-Cavalletto - Chassis-Central stand - Châssis-Bequille - Rahmen-Ständer - Chasis-
Caballete

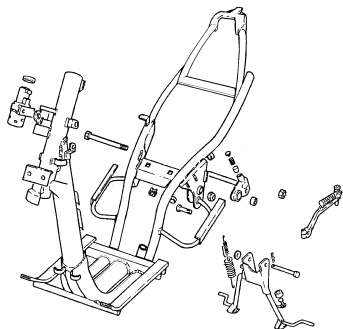

TAV.16 Coperture - Protection covers - Carters - Verkleidungen - Tapas

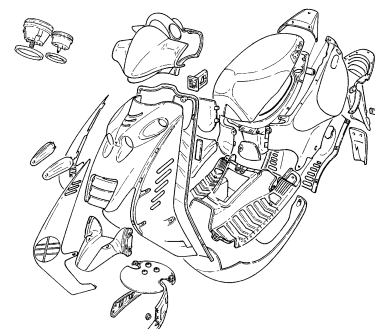

Tav.1

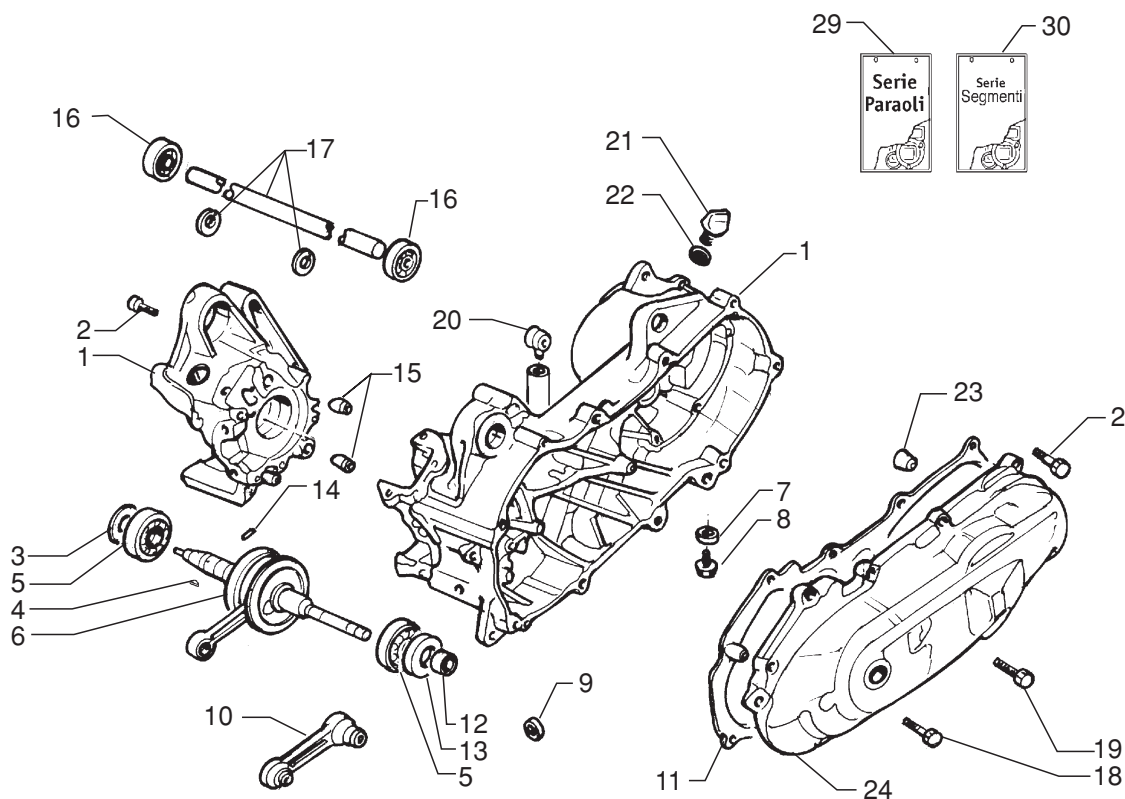

Pos Loc Pos Ps Pos	Numero Number Número Numero	Q.tà Q.ty Q.té Cant M.ge	Nota Note Note Nota Anm.	Descrizione	Description	Désignation	Beschreibung	Descripción
1	33-02060	1		Coppia carter	Crankcase pair	Paire carter	Gehäusepaar	Par cárter
2	31-48510	10		Vite t.c.c.e M6x35	Screw t.c.c.e M6x35	Vis t.c.c.e M6x35	Schraube t.c.c.e M6x35	Tornillo t.c.c.e M6x35
3	33-01440	1		Paraolio 20x30/33,5x5,5	Oil seal 20x30/33,5x5,5	Pare-huile 20x30/33,5x5,5	Dichtring 20x30/33,5x5,5	Sello de lub. 20x30/33,5x5,5
4	33-00450	1		Chiavetta volano d.13x3	Flywheel key d.13x3	Clavette volant d.13x3	Schwungradschlüssel d.13x3	Chaveta volante d.13x3
5	33-00710	2		Cuscinetto 20x47x14	Bearing 20x47x14	Roulement 20x47x14	Lager 20x47x14	Cojínete 20x47x14
6	33-01010	1		Imbiellaggio	Crankshaft	Vilebrequin	Kurbelwelle	Cigüeñal
7	33-00760	1		Guarnizione vite scarico olio	Oil drain screw gasket	Garniture vis de vidange huile	Dichtung für Ölablaßschraube	Junta tornillo descarga aceite
8	33-00610	1		Vite t.e. M8x1,25x15 flang	Screw t.e. M8x1,25x15	Vis t.e. M8x1,25x15	Schraube t.e. M8x1,25x15	Tornillo t.e. M8x1,25x15
9	33-02070	2		Gommino chius. Fori carter	Crankcase holes sealing	Garniture ferm. trous carter	Gummistöpselchen zum Stopfen der Gehäuselöcher	Tapón de goma cierre orificios cárter
10	33-01190	1		Biella completa	Conn.-rod, assy	Bielle compl.	Pleuel, kompl.	Biela compl.
11	33-00830	1		Guarnizione.coperch.m.moto	Starting cover gasket	Garniture cov. démarrage	Dichtung für Anlaßhaube	Junta cubierta puesta en marcha
12	33-00510	1		Distanziale.cusc./paraolio friz.	Spacer Bearing Oil seal	Entretoise Roulement Pare-huile	Distanzstück Lager Dichtring	Distanciador Cojínete Sello de lub.
13	33-01450	1		Paraolio 20x42/43x8/9	Oil seal 20x42/43x8/9	Pare-huile 20x42/43x8/9	Dichtring 20x42/43x8/9	Sello de lub. 20x42/43x8/9
14	33-00870	1		Rullo d.3x11,8	Roller d.3x11,8	Rouleau d.3x11,8	Rollenkern d.3x11,8	Rulo d.3x11,8
15	33-01920	2		Grano di rifer.carter 12x16	Crankcase dowel 12x16	Goujon de réf. carter 12x16	Bezugszapfen für 12 x 16 Gehäuse	Clavija posicionadora cárter 12x16
16	33-00700	2		Cuscinetto 17x35x10	Bearing 17x35x10	Roulement 17x35x10	Lager 17x35x10	Cojínete 17x35x10
17	33-02210	1		Distanziale.12x17x227+seeg	Spacer 12x17x227+seeg	Entretoise 12x17x227+seeg	Distanzstück 12x17x227	Distanciador 12x17x227+seeg
18	31-36010	12		Vite t.c.c.e. M6x25	Screw t.c.c.e. M6x25	Vis t.c.c.e. M6x25	Schraube t.c.c.e. M6x25	Tornillo t.c.c.e. M6x25
19	31-55510	1		Vite t.c.c.e. M6x45	Screw t.c.c.e. M6x45	Vis t.c.c.e. M6x45	Schraube t.c.c.e. M6x45	Tornillo t.c.c.e. M6x45
20	33-01810	1		Raccordo per sfiato	Breather pipe	Raccord pour vidange	Entlüftungsrohranschluß	Racor para ventilación
21	33-00170	1		Tappo olio alimentaz.	Oil plug	Bouchon approv. huile	Öleinfüllstopfen	Tapón aceite alimentación
22	33-01380	1		Anello or13,3x2,4	Ring 13,3x2,4	Circlips 13,3x2,4	Ring 13,3x2,4	Anillo 13,3x2,4
23	33-01930	1		Grano rif.cop.friz 10x14	Dowel 10x14	Repère 10x14	Passtift 10x14	Centraje 10x14
24	33-01170-057	1		Coperchio m.moto	Starting cover	Couvercle démarrage	Anlaßhaube	Cubierta puesta en marcha
29	33-02280	1		Serie anelli paraolio	oil seal rings set	Jeu joints spi	Öldichtungsringsatz	Serie anillos guardagotas
30	33-02310	1		Serie segmenti d.40,5	Ring set d.40,5	Serie segments d.40,5	Set Kolberringe d.40,5	Serie segmentos d.40,5

Tav.2

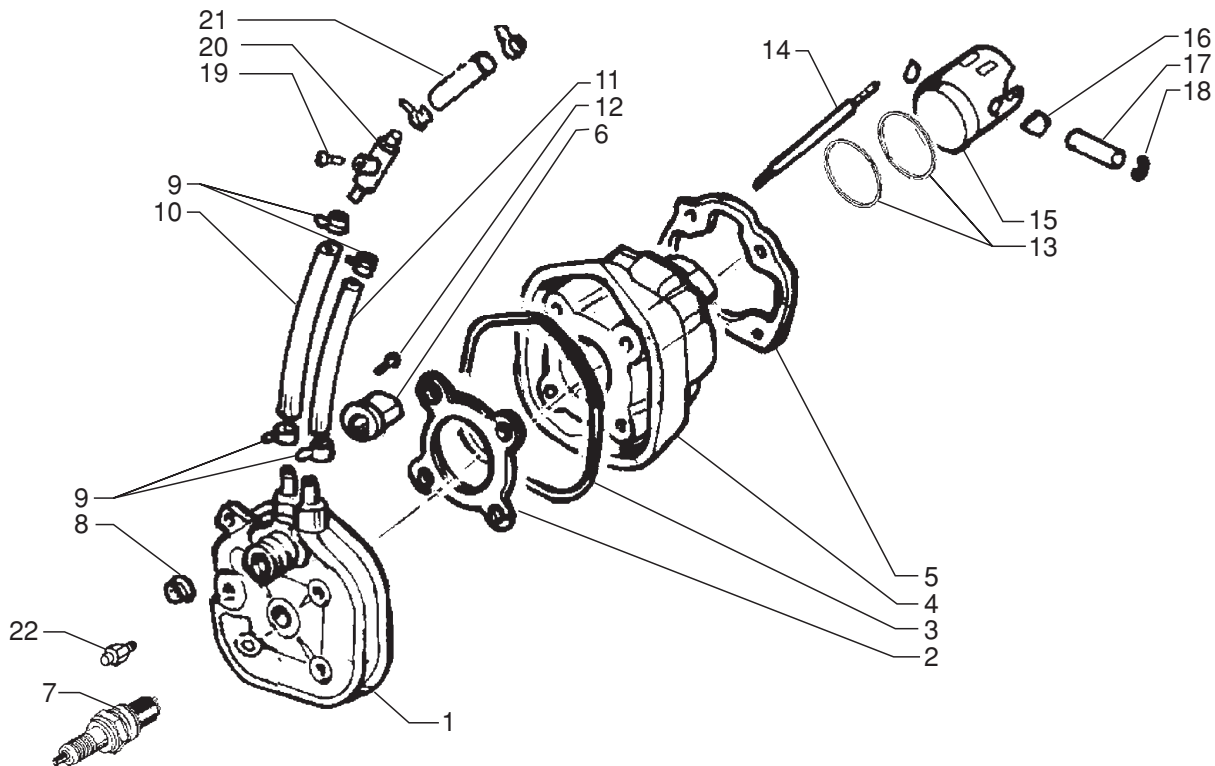

Pos Loc Pos Ps Pos	Numero Number Número Número Nummer	Q.tà Q.ty Q.té Cant M.ge	Nota Note Note Nota Anm.	Descrizione	Description	Désignation	Beschreibung	Descripción
1	33-02420	1		Testa	Cylinder head	Culasse	Kopf	Culata
2	33-02260	1		O-Ring per interno testa	O-ring for head inside	Joint torique d'étanchéité intér. tête	O-Ring für Kopfinnenseite	O-ring para interior culata
3	33-02250	1		O-Ring esterno per testa	External O-ring for head	Joint torique d'étanchéité exter. tête	O-Ring für Kopfaußenseite	O-ring exterior para culata
4	33-02000	1		Cilindro	Cylinder	Cylindre	Zylinder	Cilindro
5	33-02110	1		Guarnizione.base cilindro	Cylinder base gasket	Garniture base cylindre	Dichtung für Zylinderfuß	Junta base cilindro
6	33-02150	1		Termostato	Bimetal, thermostatic	Thérmostat	Thermostat	Termostato
7	12-25190	1		Candela Champion	Spark plug Champion	Bougie Champion	Zundkerze Champion	Bujia Champion
8	33-00500	4		Dado M7x1 h.7 ch10 flan.	Nut M7x1 h.7 ch10	Ecrou M7x1 h.7 ch10	Mutter M7x1 h.7 ch10	Tuerca M7x1 h.7 ch10
9	33-02370	4		Clic fermatubo	Hose clamp	Clip	Rohrspanning	Clic sujetatubo
10	33-02380	1		Tubo.coll.-racc.sfiato	Breather pipe cross-connection	Tuyau coll.-racc. vidange	Entlüftungsanschlußverbindungsrohr	Tubo conexión racor ventilación
11	33-02410	1		Tubo coll.testa-carb.	Carburettor-head cross-connection	Tuyau coll.-tête-carb.	Vergaser und Kopfteil verbindendes Rohr	Tubo conexión culata - carburador
12	31-24500	2		Vite t.c.ic. M4x8	Screw t.c.ic. M4x8	Vite M10x1,25x45	Schraube t.c.ic. M4x8	Tornillo t.c.ic. M4x8
13	33-00980	1		Serie segmenti	Ring set	Serie segments	Set Kolberringe	Serie segmentos
14	33-00530	4		Prigioniero.M7x1x109 fis.tes.	Stud M7x1x109 fis.tes.	Goujon M7x1x109 fis.tes.	Stiftschraube M7x1x109 fis.tes.	Espárrago M7x1x109 fis.tes.
15	33-02290	1		Pistone completo d.40	Piston set d.40	Piston compl. d.40	Kolben, kompl. d.40	Pistón, compl.d.40
16	33-00720	1		Gabbia spinotto	Piston pin cage	Cage axe de piston	Bolzenkäfig	Jaula pasador
17	33-00890	1		Spinotto 10x33	Pin 10x33	Axe 10x33	Zapfen 10x33	Eje 10x33
18	33-00080	1		Anello ferma spinotto	Piston pin lock ring	Bague de serrage goujon	Bolzenfeststellring	Anillo sujeta pasador
19	31-2336	1		Vite di sfiato	Drain screw	Vis de vidange	Entlüfterschraube	Tornillo de ventilación
20	33-02400	1		Raccordo sfiato	Breather pipe	Raccord pour vidange	Entlüftungsrohranschluß	Racor ventilación
21	33-02390	1		Tubo.coll.-racc.sfiato-carb.	Carburettor breather pipe cross connec.	Tuyau coll.-racc.vidange-carb.	Entlüfteranschluß und Vergaser	Tubo conexión racor ventil. carbur.
22	29-11958	1		Termointerruttore	Thermal switch	Thermo- régulateur	Umschalter	Interruptor térmico

Tav.3

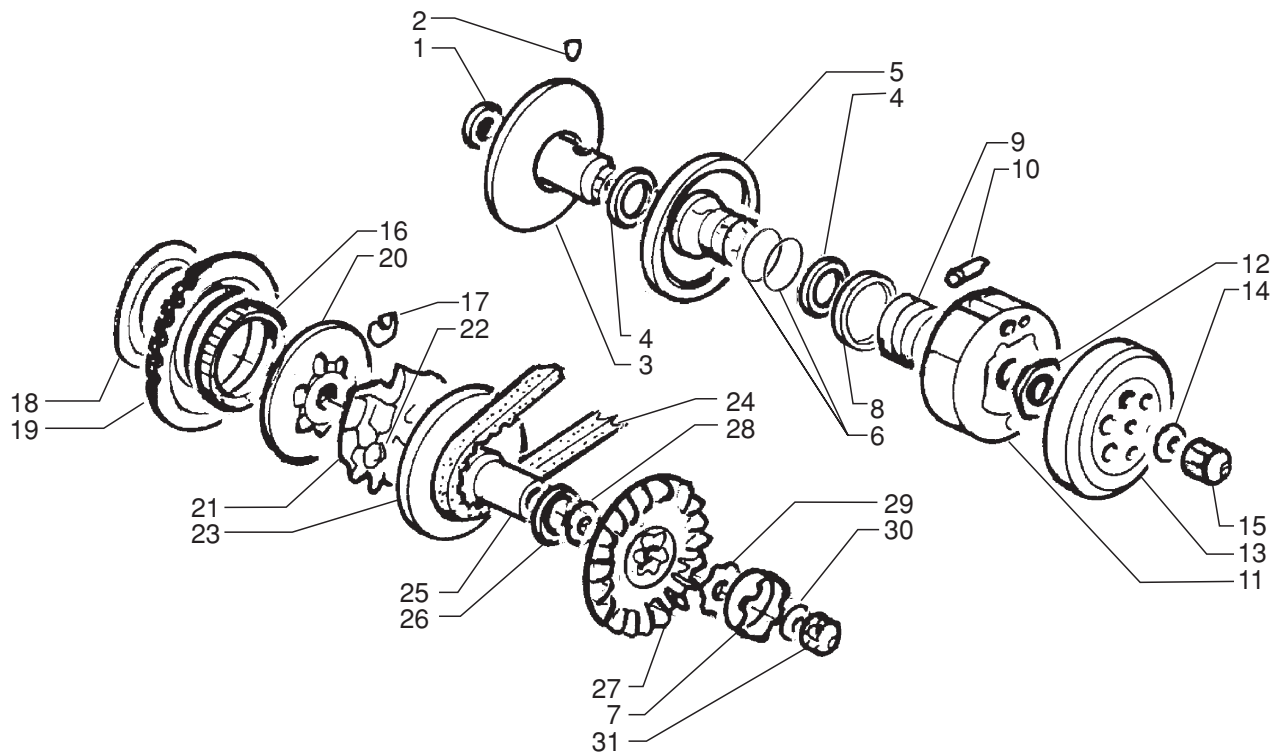

Pos Loc Pos Ps Pos	Numero Number Número Número	Q.tà Q.ty Q.té Cant M.ge	Nota Note Note Nota Anm.	Descrizione	Description	Désignation	Beschreibung	Descrìcion
1	33-01460	1		Paraolio 17x28x5,5	Oil seal 17x28x5,5	Pare-huile 17x28x5,5	Dichtring 17x28x5,5	Sello de lub. 17x28x5,5
2	33-00880	1		Rullino guida per variat.	Roller	Rouleau	Rolle	Rodillo
3	33-00230	1		Puleg.sec.fissa compl.	Secondary fixed pulley assembly	Poulie sect. fixe compl	feste Sekundärriemenscheibe	Polea secundaria fija completa
4	33-00790	2		Paraolio 32x39x4	Oil seal 32x39x4	Pare-huile 32x39x4	Dichtring 32x39x4	Sello de lub. 32x39x4
5	33-00240	1		Puleg.sec.mob.compl.	Secondary mobile pulley assembly	Poulie sect. mob. compl.	bewegliche Sekundärriemenscheibe	Polea secundaria móvil completa
6	33-00730	2		Anello or37,5x1,7	Ring 37,5x1,7	Circlips 37,5x1,7	Ring 37,5x1,7	Anillo 37,5x1,7
7	33-00270	1		Scodellino dent.m.moto.	Starting indented cup	Rondelle dent. démarrage	gezahnter Anlaßsteller	Platillo dentado puesta en marcha
8	33-00260	1		Scodellino portamol.var.	Stop washer	Rondelle d'ar	Federaufnahme	Muelle
9	33-00370	1		Mollapuleg.sec.mobile	Mobile secondary pulley spring	Ressort poulie sec. mobile	Feder für Sekundärlosscheibe	Muelle polea secundaria móvil
10	33-02100	2		Molla rich.ceppi frizione	Clutch shoes return spring	Ressort de rappel sabots embrayage	Kupplungsbackenrückzugsfeder	Muelle de retorno zapatas embrague
11	33-02090	1		Frizione.centrifuga compl.	Centrifugal clutch assembly	Embrayage centrifugeuse compl.	Zentrifugalkupplung kompl.	Embrague centrifugo completo
12	33-00490	1		Dado M28x1	Nut M28x1	Ecrou M28x1	Mutter M28x1	Tuerca M28x1
13	33-00220	1		Campana frizione compl.	Clutch case assembly	Cloche d'embrayage compl.	Kupplungsglocke.	Campana de embr.completa
14	33-00540	1		Rondella bisel.10x21x2	Washer 10x21x2	Rondelle 10x21x2	U.Scheibe 10x21x2	Arandela 10x21x2
15	33-00480	1		Dado M10x1	Nut M10x1	Ecrou M10x1	Mutter M10x1	Tuerca M10x1
16	33-01130	1		Gabbia 57x61x10	Cage 57x61x10	Cage 57x61x10	Lagerkäfig 57x61x10	Jaula 57x61x10
17	33-00180	3		Tassello di traino	Draft gear	Crochet de remorq.	Zugvorrichtung	Dispositivo de arrastre
18	33-00640	1		Boccola flang.per corona	Flanged bush for gear	Douille à brides pour couronne	Kranzflanschbuchse	Buje con reborde para corona
19	33-01080	1		Corona avviam.elettrico	Electric starting gear	Couronne démarrage électrique	Kranz für elektrisches Anlassen	Corona arranque eléctrico
20	33-00340	1		Ruota completa iberà	Freewheel assembly	Roue libre complète	Freilauf kompl.	Rueda completa libre
21	33-00250	1		Cappello porta tasselli	Pad carrier cap	Chapeau porte chevilles	Gleitschuhträgerkappe	Capuchón porta zapatas
22	33-02130	1		Massa centrifuga 9,5	Centrifugal weights 9,5	Masselotte centrifuge 9,5	Masse Schlanderbacken 9,5	Masa cenjtrifuga 9,5
23	33-00910	1		Puleggia anteriore mobile	Mobile front pulley	Poulie av. mobile	Riemenscheibe hinten	Polea delantera móvil
24	33-01290	1		Cinghia di trasmissione	Transmission belt	Courroie de transmission	Übertragungsriemen	Correa de transmisión
25	33-00660	1		Boccolapuleg.ant.mobile	Front mobile pulley bush	Douille poulie ant. mobile	Buchse für Vorderlosscheibe	Buje polea delantera móvil
26	33-02120	1		Distanziale 18x23x5	Spacer 18x23x5	Entretoise 18x23x5	Distanzstück 18x23x5	Distanciadador 18x23x5
26	33-02121	1	EURO 1-2	Distanziale 18x23x6	Spacer 18x23x6	Entretoise 18x23x6	Distanzstück 18x23x6	Distanciadador 18x23x6
27	33-00930	1		Semipuleggia fissa anteriore	Front fixed half pulley	Semi poulie fixe antérieure	feste Vorderscheibenhälfte	Semipolea fija delantera
28	33-02220	1		Rondella acc. 3x18,5x1	Washer 3x18,5x1	Rondelle 3x18,5x1	U.Scheibe 3x18,5x1	Arandela 3x18,5x1
29	33-00290	1		Piastrina. Traino pul.ant.fissa	Front fixed pulley driving plate	Plaq. Entraînement poulie ant. fixe	Zugplättchen für feste Vorderscheibe	Placa de arrastre polea delantera fija
30	33-00580	1		Rondella 10,5x18x2	Washer 10,5x18x2	Rondelle 10,5x18x2	U.Scheibe 10,5x18x2	Arandela 10,5x18x2
31	33-00470	1		Dado M10x1,25	Nut M10x1,25	Ecrou M10x1,25	Mutter M10x1,25	Tuerca M10x1,25

Tav.4

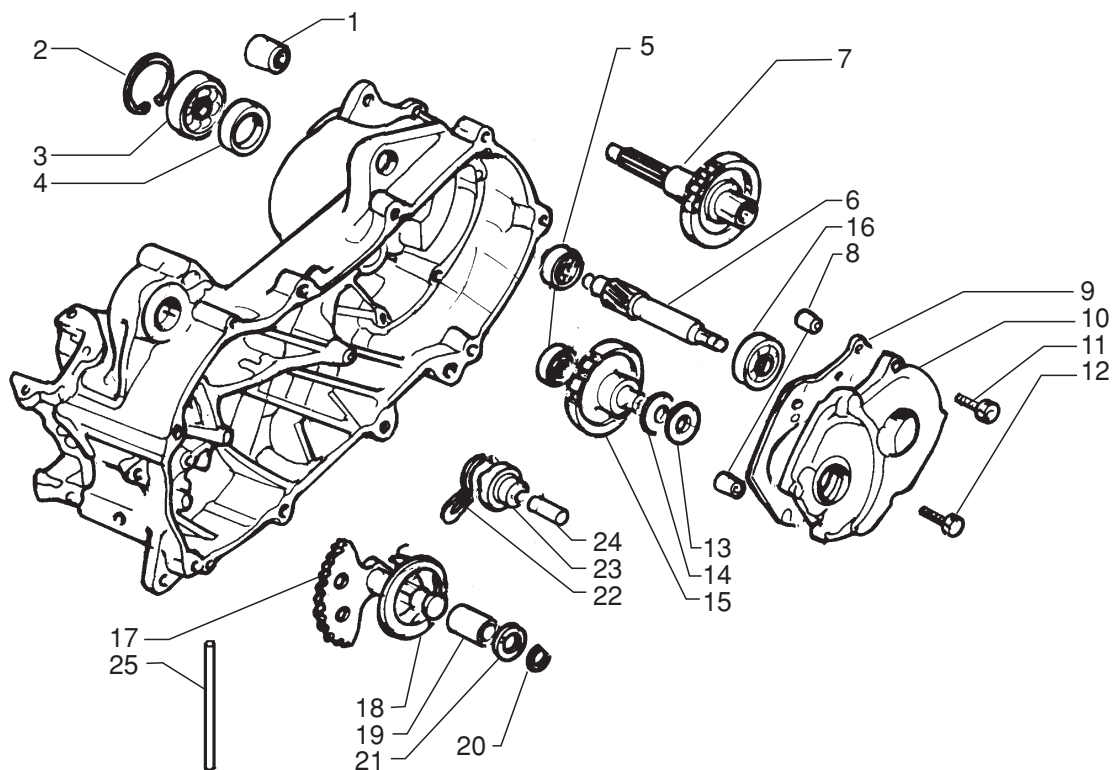

Pos Loc Ps Pos	Numero Number Número Número	Q.tà Q.ty Q.té Cant M.ge	Nota Note Note Nota Anm.	Descrizione	Description	Désignation	Beschreibung	Descripció
1	33-00190	1		Silentbloc	Silentbloc	Silentbloc	Puffer	Silent-block
2	33-00060	1		Anello seeger per foro d.40	Snap ring for hole d.40	Anneau de retenue pour trou d.40	Seegerring für 40 Durchmesser Loch	Anillo retención orificio diámet. 40
3	33-01420	1		Cuscinetto 17x40x12	Bearing 17x40x12	Roulement 17x40x12	Lager 17x40x12	Cojinete 17x40x12
4	33-01470	1		Paraolio 22x32x6	Oil seal 22x32x6	Pare-huile 22x32x6	Dichtring 22x32x6	Sello de lub. 22x32x6
5	33-00690	1		Cuscinetto 10x30x9	Bearing 10x30x9	Roulement 10x30x9	Lager 10x30x9	Cojinete 10x30x9
6	33-01330	1		Albero di trasmissione	Propeller shaft & universal joint	Arbre de transmission	Hauptwelle	Eje de transmision
7	33-01870	1		Albero uscita compl.	Output shaft assembly	Arbre sortie compl.	Ausgangswelle	Árbol salida completa
8	33-01930	2		Grano rif.cop.friz 10x14	Dowel 10x14	Repère 10x14	Passift 10x14	Centraje 10x14
9	33-00820	1		Guarnizione coperchio trasmissione	Packing Transmission cover	Joint Couvercle transmission	Dichtung Getriebeabdeckung	Junta Tapa transmision
10	33-00130	1		Coperchio trasmissione	Transmission cover	Couvercle transmission	Getriebeabdeckung	Tapa transmision
11	31-48510	10		Vite t.c.c.e M6x35	Screw t.c.c.e M6x35	Vis t.c.c.e M6x35	Schraube t.c.c.e M6x35	Tornillo t.c.c.e M6x35
12	31-34510	10		Vite t.c.c.e. M6x20	Screw t.c.c.e M6x20	Vis t.c.c.e M6x20	Schraube t.c.c.e M6x20	Tornillo t.c.c.e M6x20
13	33-00620	1		Rondella acc.14x29x1	Washer 14x29x1	Rondelle 14x29x1	U.Scheibe 14x29x1	Arandela 14x29x1
14	33-00410	1		Molla a disco reggispinta	Thrust bearing leaf spring	Ressort à disque de butée	Drucklagerscheibenfeder	Muelle de disco cojinete de tope
15	33-01860	1		Ingr.doppio inter.compl.	Double idler gear assembly	Pignon double int. compl.	Doppelzwischenradeinheit	Engranaje doble intermedio completo
16	33-00670	1		Cuscinetto 17x40x12	Bearing 17x40x12	Roulement 17x40x12	Lager 17x40x12	Cojinete 17x40x12
17	33-00030	1		Albero messa in moto compl.	Starting shaft assembly	Arbre démarrage compl.	Anlaßwelle kompl.	Árbol puesta en marcha completo
18	33-00400	1		Molla rit.leva m.moto	Starting lever pullback spring	Ressort retenue manette démarrage	Anlaßhebelhaltefeder	Muelle retención pal. puesta en marcha
19	33-00630	1		Boccola albero m.moto	Starting shaft bush	Douille arbre démarrage	Anlaßwellenbuchse	Buje árbol puesta en marcha
20	33-00040	1		Anello seeger per albero d.15	Snap ring for shaft d.15	Anneau de retenue pour arbre d.15	Seegerring für 15 Durchmesser Welle	Anillo retención para árbol diám. 15
21	33-00560	1		Rondella acc.15,1x28x1	Washer 15,1x28x1	Rondelle 15,1x28x1	U.Scheibe 15,1x28x1	Arandela 15,1x28x1
22	33-00380	1		Molla scorrevole m.moto	Starting sliding spring	Ressort coulissant démarrage	Anlaßschiebefeder	Muelle corredizo puesta en marcha
23	33-00330	1		Ingran.scorr.m.moto	Starting sliding gear	Pignon ball. démarreur	Anlaßschieberad	Engranaje deslizante puesta movim.
24	33-00860	1		Perno 8x32	Pin 8x32	Pivot 8x32	Zapfen 8x32	Perno 8x32
25	33-01810	1		Raccordo per sfiato	Breather pipe	Raccord pour vidange	Entlüftungsrohranschluß	Racor para ventilación

Tav.5

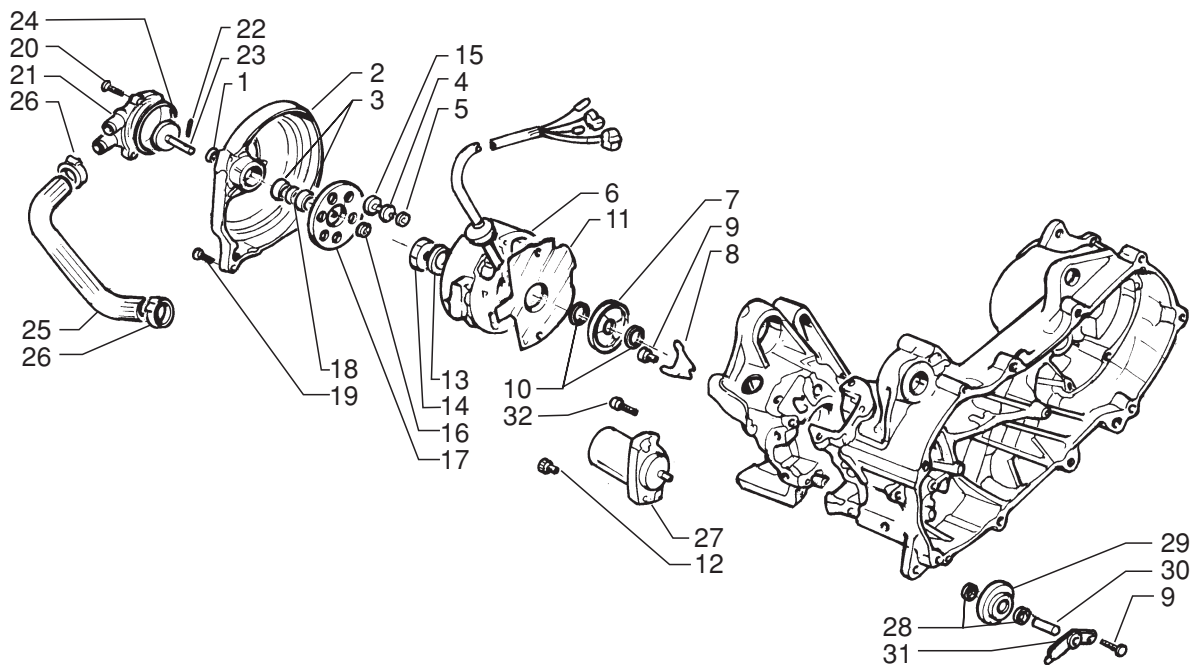

Pos Loc Pos Ps Pos	Numero Number Numéro Número Nummer	Q.tà Q.ty Q.té Cant M.ge	Nota Note Note Nota Anm.	Descrizione	Description	Désignation	Beschreibung	Descrìcion
1	10-44610	1		Paraolio 10x18x4	Oil seal 10x18x4	Pare-huile 10x18x4	Dichtring 10x18x4	Sello de lub. 10x18x4
2	33-02040	1		Coperchio volano	Flywheel cover	Carter volant	Schwungraddeckel	Tapa volante
3	33-02230	2		Cuscinetto 8x22x7	Bearing 8x22x7	Roulement 8x22x7	Lager 8x22x7	Cojinete 8x22x7
4	33-02160	1		Perno traino vent.acqua	Water disc drive pin	Axe entrainement disque.eau	Zugzapfen für Wasserflügelrad	Perno de arrastre disco agua
6	31-03250	1		Volano magnete	Flywh.magn.	Volant magnetique	Lichtmaschine, kpl.	Volante magn.
6	33-01051	1	EURO 2	Volano magnete	Flywh.magn.	Volant magnetique	Lichtmaschine, kpl.	Volante magn.
7	33-00350	1		Ingran.cond.olio pompa	Pump oil drive gear	Engrenage cond. huile pompe	Getriebe zur Pumpenölleitung	Engranaje tubería aceite bomba
8	33-00280	1		Piastrina.ritegno paraolio	Oil seal stop plate	Plaque retenue défecteur d'huile	Ölabdichtungshalteplättchen	Placa retención guardagotas
9	33-01950	3		Vite t.c.c.e.M6x12 R.80	Screw t.c.c.e.M6x12 R.80	Vis t.c.c.e.M6x12 R.80	Schraube t.c.c.e.M6x12 R.80	Tornillo t.c.c.e.M6x12 R.80
10	33-00070	2		Anello seeger per albero d.19	Snap ring for shaft d.19	Anneau de retenue pour arbre d.19	Seeger. für 19 Durchmesser Welle	Anillo de retención árbol diám. 19
11	33-01140	1		Guarnizione.statore volano	Flywheel stator gasket	Garniture stator volant	Dichtung für Schwungradstator	Dichtung estator volante
12	31-31050	2		Vite t.c.c.e.M6x15	Screw t.c.c.e.M6x15	Vis t.c.c.e.M6x15	Schraube t.c.c.e.M6x15	Tornillo t.c.c.e.M6x15
13	33-00580	1		Rondella 10,5x18x2	Washer 10,5x18x2	Rondelle 10,5x18x2	U.Scheibe 10,5x18x2	Arandela 10,5x18x2
14	33-00470	1		Dado M10x1,25	Nut M10x1,25	Ecrou M10x1,25	Mutter M10x1,25	Tuerca M10x1,25
15	33-02080	1		Gommino perno traino	Drive pin rubber	Garniture caoutchouc axe entrainem.	Gummidichtung für Zugzapfen	Tapón de goma perno de arrastre
16	28-22650	1		Seeger d.8	Snap ring d.8	Circlip d.8	Seegerring d.8	Anillo Seeger d.8
17	33-02200	1		Traino per ventola acqua	Draft for water fan	Entrain. turbine	Wasserlüfterradzug	Arrastre para impulsor agua
18	33-02125	1		Distanziale 21,9x17,5x4,5	Spacer 21,9x17,5x4,5	Entretoise 21,9x17,5x4,5	Distanzstück 21,9x17,5x4,5	Distanciador 21,9x17,5x4,5
19	31-36010	12		Vite t.c.c.e. M6x25	Screw t.c.c.e. M6x25	Vis t.c.c.e. M6x25	Schraube t.c.c.e. M6x25	Tornillo t.c.c.e. M6x25
20	31-30010	3		Vite t.c.c.e M5x18	Screw t.c.c.e M5x18	Vis t.c.c.e M5x18	Schraube t.c.c.e M5x18	Tornillo t.c.c.e M5x18
21	33-02190	1		Pompa acqua	Water pump	Pompe à eau	Wasserpumpe	Bomba acqua
22	33-02170	1		Rullo d.3x21,8	Roller d.3x21,8	Rouleau d.3x21,8	Rollenkern d.3x21,8	Rulo d.3x21,8
23	33-02140	1		Perno pompa acqua	Water pump pin	Axe pompe à eau	Wasserpumpenzapfen	Perno bomba acqua
24	10-672120	1		O-ring 53,7x1,78	O-Ring 53,7x1,78	O-Ring 53,7x1,78	O-Ring 53,7x1,78	O-Ring 53,7x1,78
25	33-02240	1		Tubo pompa-cilindro	Pump-cylinder tube	Tuyau pompe-cylindre	Pumpen-Zylinder-Rohr	Tubo bomba - cilindro
27	33-00420	1		Motorino avviamento	Starter motor	Moteur du démarreur	Startermotor	Motor de arranque
28	33-00590	2		Rondella 8x16x2	Washer 8x16x2	Rondelle 8x16x2	U.Scheibe 8x16x2	Arandela 8x16x2
29	33-00320	1		Ingr.doppio interm.	Double idler gear	Engr. double inter.	doppeltes Zwischenrad	Engranaje doble intermedio
30	33-00860	1		Perno 8x32	Pin 8x32	Pivot 8x32	Zapfen 8x32	Perno 8x32
31	33-01350	1		Piastrina ingr.doppio intr.	Double idler gear plate	Plaque engr. interm. double	Plättchen für Doppelzwischenrad	Placa engranaje doble intermedio

Tav.6

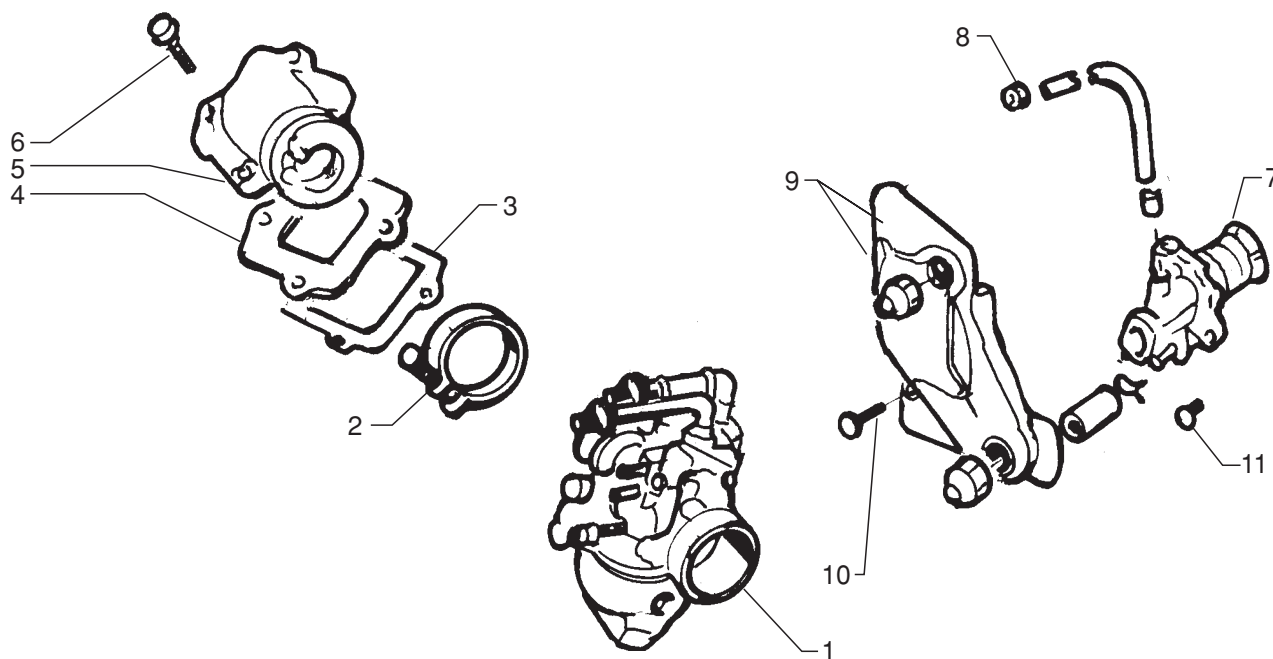

Pos Loc Ps Pos	Numero Number Numéro Número Nummer	Q.tà Q.ty Q.té Cant M.ge	Nota Note Note Nota Anm.	Descrizione	Description	Désignation	Beschreibung	Descripció
1	33-02020	1		Carburatore PHVA 12-PS/R.1437	Carburettor PHVA 12-PS/R.1437	Carbureteur PHVA 12-PS/R.1437	Vergaser PHVA 12-PS/R.1437	Carburador PHVA 12-PS/R.1437
1	33-02610	1	EURO 1	Carburatore PY 12/R.407	Carburettor PY 12/R.407	Carbureteur PY 12/R.407	Vergaser PY 12/R.407	Carburador PY 12/R.407
1	33-02860	1	EURO 2	Carburatore PY 12/R.437	Carburettor PY 12/R.437	Carbureteur PY 12/R.437	Vergaser PY 12/R.437	Carburador PY 12/R.437
2	33-00430	1		Fascetta flangia aspiraz.	Clamp Flange	Collier Bride	Schelle Flansch	Abrazadera Brida
3	33-00840	1		Guarnizione.valvola lamelle	Strip valve gasket	Garniture soupape à lamelles	Dichtung für Lamellenventil	Junta válvula láminas
4	33-01410	1		Valvola lamelle	Strip valve	Soupape à lamelles	Lamellenventil	Válvula láminas
5	33-01520	1		Collettore aspirazione Ø20	Inlet manifold Ø20	Collecteur Admission Ø20	Ansaugstutzen Ø20	Colector aspiración Ø20
6	31-34510	4		Vite t.c.c.e. M6x20	Screw t.c.c.e M6x20	Vis t.c.c.e M6x20	Schraube t.c.c.e M6x20	Tornillo t.c.c.e M6x20
7	33-01320	1		Pompa olio	Oil pump	Pompe huile	Ölpumpe	Bomba aceite
8	33-00440	2		Fascetta tubo pompa olio	Oil pump hose clamp	Collier tube déflecteur d'huile	Ölpumpenrohrschelle	Abrazadera tubo bomba aceite
9	33-02050	1		Coperchietto su cop.vol.	Cover on flywheel housing	Petit couvercle sur couv. vol.	Deckel auf Schwungradbezug	Tapa sobre cubrevolante
10	31-29850	2		Vite t.t.l.c. M5x12	Screw t.t.l.c. M5x12	Vis t.t.l.c. M5x12	Schraube t.t.l.c. M5x12	Tornillo t.t.l.c. M5x12
11	33-01940	2		Vite t.c.c.e. M5x14	Screw t.c.c.e. M5x14	Vis t.c.c.e. M5x14	Schraube t.c.c.e. M5x14	Tornillo t.c.c.e. M5x14

Tav.7

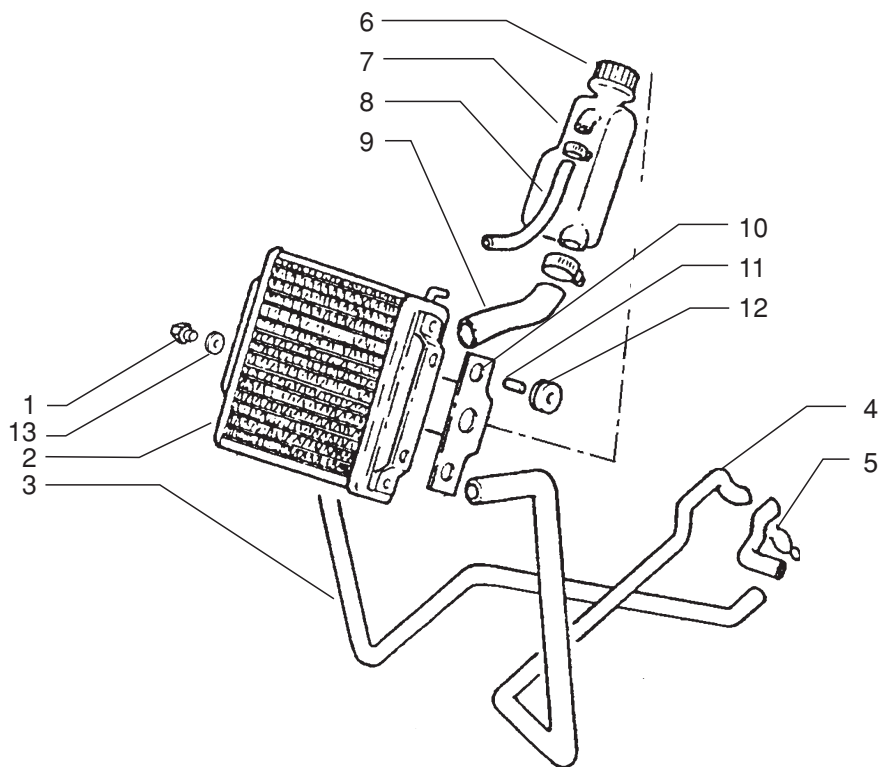

Pos Loc Pos Ps Pos	Numero Number Número Nummer	Q.tà Q.ty Q.té Cant M.ge	Nota Note Note Nota Anm.	Descrizione	Description	Désignation	Beschreibung	Descripción
1	29-01270	1		Tappo radiatore	Cooler cap	Bouchon du radiateur	Kühlerverschluss	Tapón radiador
2	27-23730	1		Radiatore	Cooler	Radiateur	Kühler	Radiador
3	22-13681	1		Manicotto uscita testa	Head output sleeve	Manchon sortie tête	Kopfauslaufmuffe	Manguito salida culata
4	22-13680	1		Manicotto ingresso pompa	Pump input sleeve	Manchon entrée pompe	Pumpeneinlaufmuffe	Manguito entrada bomba
5	22-65020	1		Molla tubo miscelatore	Pipe spring	Ressort tuyau	Rohrfeder	Muelle tubo
6	29-01820	1		Tappo serbatoio	Filler cap	Bouchon de réservoir	Tankverschluss	Tapón depósito
7	28-05470	1		Serb. recupero liquido	Liquid recovery tank	Cuve récupération liquide	Auffangwanne	Cuba recogedor de liquido
8	29-15863	1		Tubo sfiato	Breather tube	Tuyau réinflard	Entlüftungsleitung	Tubo respiradero
9	29-15961	2		Tubo Serbatoio liquido	Liquid tank pipe	Tuyau Réservoir liquide	Flüssigkeitsbehälterrohr	Tubo depósito liquido
10	28-97420-052	1		Staffa supporto radiatore	Radiator bracket	Bride support radiateur	Kühlertragbügel	Estribo soporte radiador
11	11-28500	1		Distanziale	Spacer	Entretoise	Distanzstück	Distanciador
12	28-91500	2		Silent-block	Silentbloc	Silent block	Puffer	Silent block
13	16-50510	1		Guarnizione	Gasket	Joint	Dichtung	Junta

Tav.8

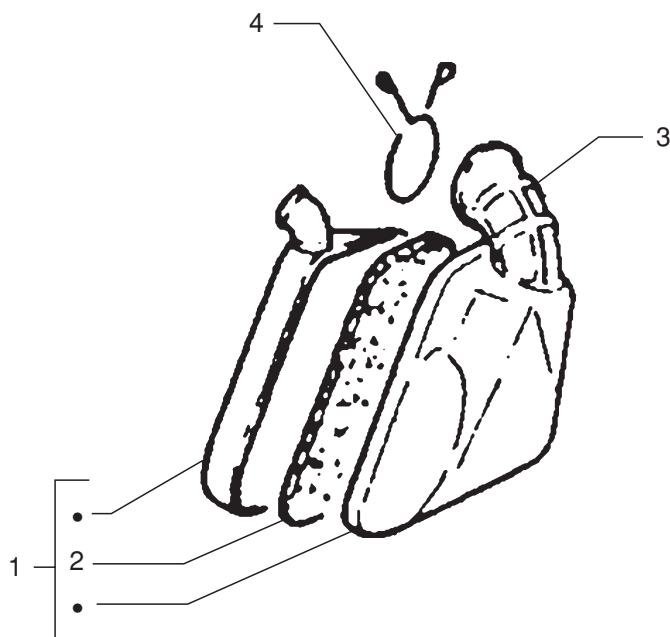

Pos Loc Pos Ps Pos	Numero Number Numéro Número Nummer	Q.tà Q.ty Q.té Cant M.ge	Nota Note Note Nota Anm.	Descrizione	Description	Désignation	Beschreibung	Descripcìon
1	28-12761-8	1		Scatola filtro completa	Air cleaner box	Boîtier filtre à air	Luffiltergehäuse	Caja filtro de aire
2	15-25070	1		Filtro	Filter	Filtre	Filter	Filtro
3	22-13662	1		Manicotto scatola filtro	Filter box sleeve	Manchon boîte du filtre	Filtergehäusemuffe	Manguito caja filtro
4	10-67380	1		Anello ferma manicotto	Sleeve lock ring	Bague de serrage manchon	Muffenfeststellring	Anillo sujeta manguito

Tav.9

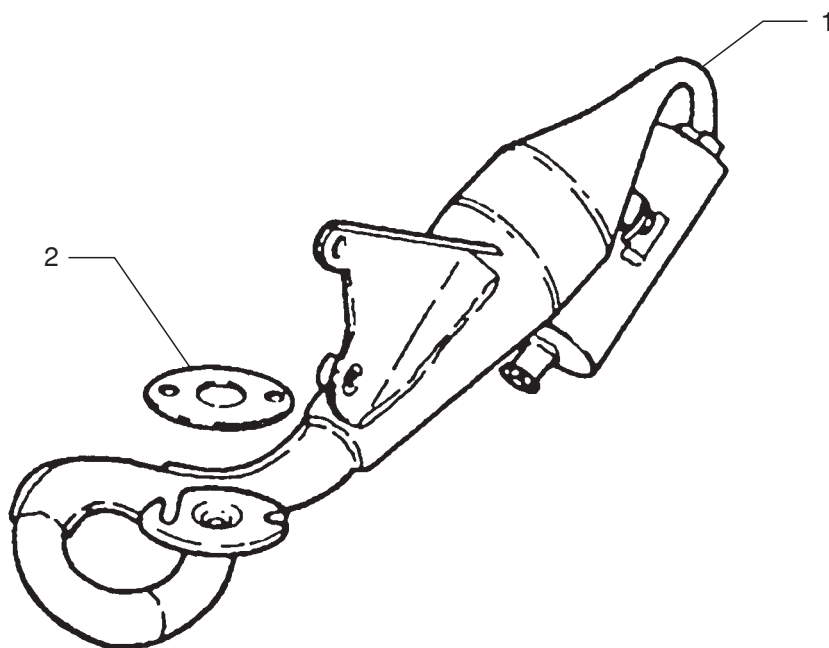

Pos Loc Pos Ps Pos	Numero Number Numéro Número Nummer	Q.tà Q.ty Q.té Cant M.ge	Nota Note Note Nota Anm.	Descrizione	Description	Désignation	Beschreibung	Descripción
1	22-04232-052	1		Marmitta	Silencer	Silencieux	Auspufftopf	Silenciador
1	22-04237	1	KAT	Marmitta catalitica	Catalytic silencer	Silencieux catalytique	Auspuff mit Katalysator	Silenciador escape catalizado
1	22-04247	1	EURO 2	Marmitta catalitica	Catalytic silencer	Silencieux catalytique	Auspuff mit Katalysator	Silenciador escape catalizado
2	16-80230	1		Guarnizione scarico	Exhaust manifold gasket	Joint coll. Ech.	Dichtung Abgaskrümmer	Junta colector de escape
2	16-80235	1	KAT	Guarnizione scarico	Exhaust manifold gasket	Joint coll. Ech.	Dichtung Abgaskrümmer	Junta colector de escape

Tav.10

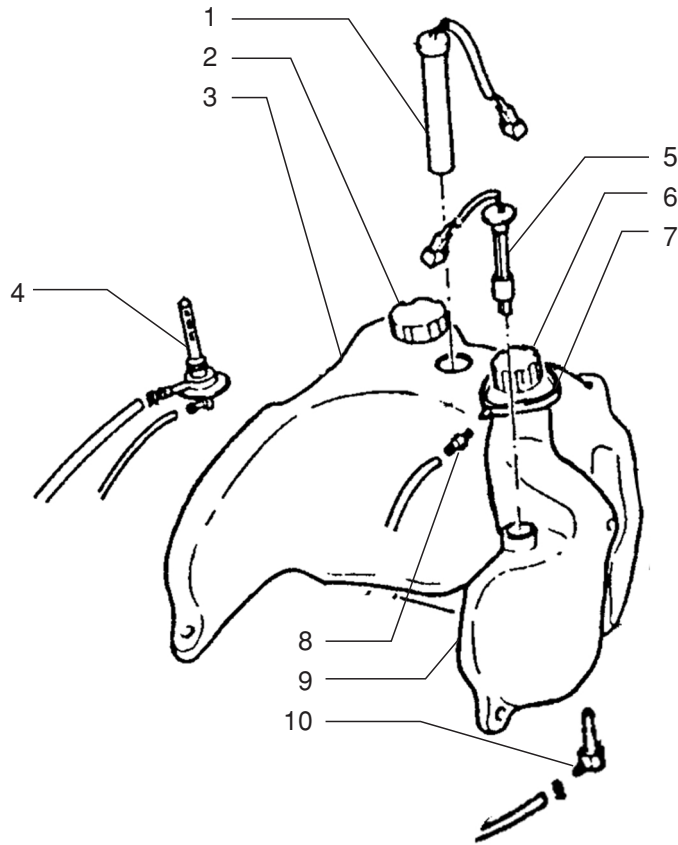

Pos Loc Pos Ps Pos	Numero Number Numéro Número Nummer	Q.tà Q.ty Q.té Cant M.ge	Nota Note Note Nota Anm.	Descrizione	Description	Désignation	Beschreibung	Descripció
1	28-93280	1		Sonda benzina	Fuel feeler	Sonde essence	Benzinfühler	Sonda gasolina
2	29-00540-052	1		Tappo serbatoio benzina	Fillercap	Bouchon réservoir essence	Benzintankverschluß	Tapón depósito gasolina
3	28-05471	1		Serbatoio benzina	Fuel tank	Reservoir carb.	Kraftstofftank	Dep. carburante
3	28-05473	1	KAT	Serbatoio benzina	Fuel tank	Reservoir carb.	Kraftstofftank	Dep. carburante
4	27-79910	1		Rubinetto depressione	Vacuum cock	Robinet dépression	Sauglufthahn	Grifo depresión
5	28-93290	1		Sonda olio	Oil feeler	Sonde huile	Ölfühler	Sonda aceite
6	29-00550	1		Tappo serbatoio olio	Oil tank plug	Bouchon réservoir d'huile	Ölbehälterverschluß	Tapón depósito aceite
7	12-93070	1		Cuffia olio	Oil guard	Coiffe huile	Ölschutz	Protección aceite
8	27-11320	1		Raccordo per cuffia	Cup fitting	Raccord pour recueil huile	Plattenanschlußstück	Racor para envoltura
9	28-05472	1		Serbatoio olio	Oil tank	Reserv.huile	Öltank	Tanque aceite
10	27-11260	1		Raccordo filtro olio	Joint piece for oil filter	Raccord du filtre huile	Stutzen für Ölfilter	Racor filtro aceite

Tav. 11

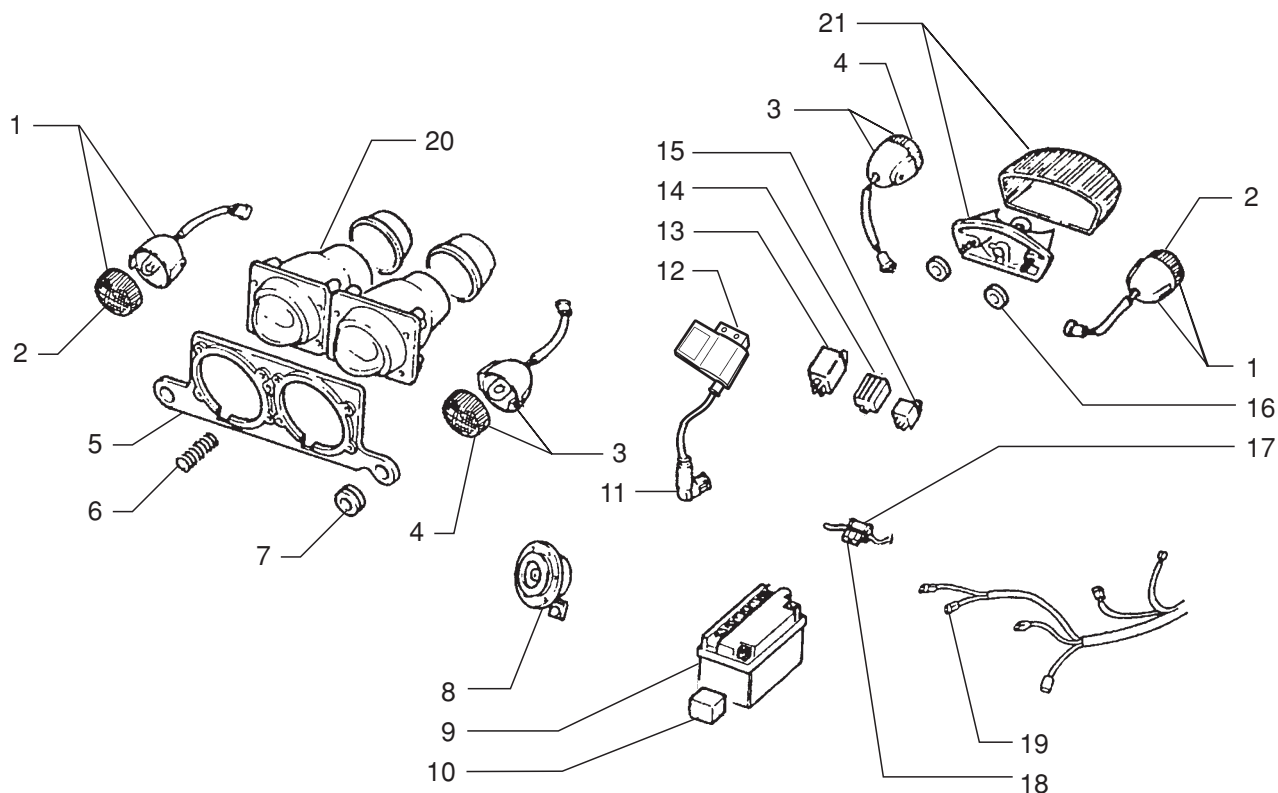

Pos Loc Pos Ps Pos	Numero Number Número Número	Q.tà Q.ty Q.té Cant M.ge	Nota Note Note Nota Anm.	Descrizione	Description	Désignation	Beschreibung	Descripció
1	18-00500-8	2		Indicatore dir. ant. dx.-post. sx	Turn signal R.H.front-L.H.rear	Clignotant av.dr.-ar.g.	Blink.Vorderer rechts-Hinterer links	Indicador del. der.-tras. izq.
2	12-81860	2		Coppetta ant.dx-post.sx	RH front-LH rear cap	Logement AV.D.-AR.G.	Rechte Vorderkappe - Linke Hinterkappe	Copa delant. derec. - trasera izquier.
3	18-00501-8	2		Indicatore dir. ant. sx.-post. dx	Turn signal L.H.front-R.H.rear	Clignotant av.g.-ar.dr.	Blink. Vorderer links-Hinterer rechts	Indicador del. izq.-tras. der.
4	12-81840	2		Coppetta ant.sx-post.dx	LH front-RH rear cap	Logement AV.G.-AR.D.	Linke Vorderkappe - Rechte Hinterkappe	Copa delantera izquier. - tras. derec.
5	28-98021-052	1		Supporto faro anteriore	Headlamp bracket	Support projecteur AV.	Scheinwerfer Träger	Soporte faro delantero
6	22-38600	1		Molla regolazione faro ant.	Front bracket adjusting spring	Ressort de réglage projecteur AV.	Scheinwerfer Feder, Einstell	Muelle de regul. faro del.
7	28-91500	2		Silent-block	Silentbloc	Silent block	Puffer	Silent block
8	10-09170	1		Avvisatore acustico	Warning horn	Avertisseur sonore	Hupe	Claxon
9	11-15410	1		Batteria	Battery	Batterie	Batterie	Bateria
10	29-10611	1		Tampone batteria	Battery pad	Tampon batterie	Batteriepuffer	Tampón batería
11	27-13550	1		Cappuccio schermato	Screened cap	Anti - Parasite	Zündkerzenstecker	Capuchon blindado
12	11-20670	1		Bobina	Coil	Bobine	Spule	Bobina
12	11-20674	1	EURO 2	Bobina	Coil	Bobine	Spule	Bobina
13	18-84940	1		Intermittenza	Unit turn signal lamps	Disp. comm. clignot.	Blinkgeber	Disp. intermitentes
14	27-27800	1		Regolatore	Regulator	Régulateur	Regler	Regulador
15	27-28460	1		Relais	Relay	Relais	Relay	Relé
16	13-46491	2		Distanziale 6,5x18x3	Spacer 6,5x18x3	Entretoise 6,5x18x3	Distanzstück 6,5x18x3	Distanciador 6,5x18x3
17	25-91780	1		Portafusibili con fusibile	Fuse carrier with fuse	Porte-fusibles avec fusible	Sicherungshalter mit Sicherungen	Portafusible con fusible
18	15-66610	1		Fusibile 5 A	Fuse 5 A	Fusible 5 A	Sicherung 5 A	Fusible 5 A
19	18-01710	1		Impianto completo	System assembly	Circuit complet	komplette Anlage	Instalación completa
19	18-01698	1	EURO 2	Impianto completo	System assembly	Circuit complet	komplette Anlage	Instalación completa
20	16-47112	1		Gruppo ottico ant.	Semi sealed front beam unit	Groupe optique AV.	Scheinwerfer vorder	Grupo óptico del.
21	15-01960	1		Fanale posteriore	Tail lamp	Feu AR.	Rückleuchte	Piloto

Tav.12

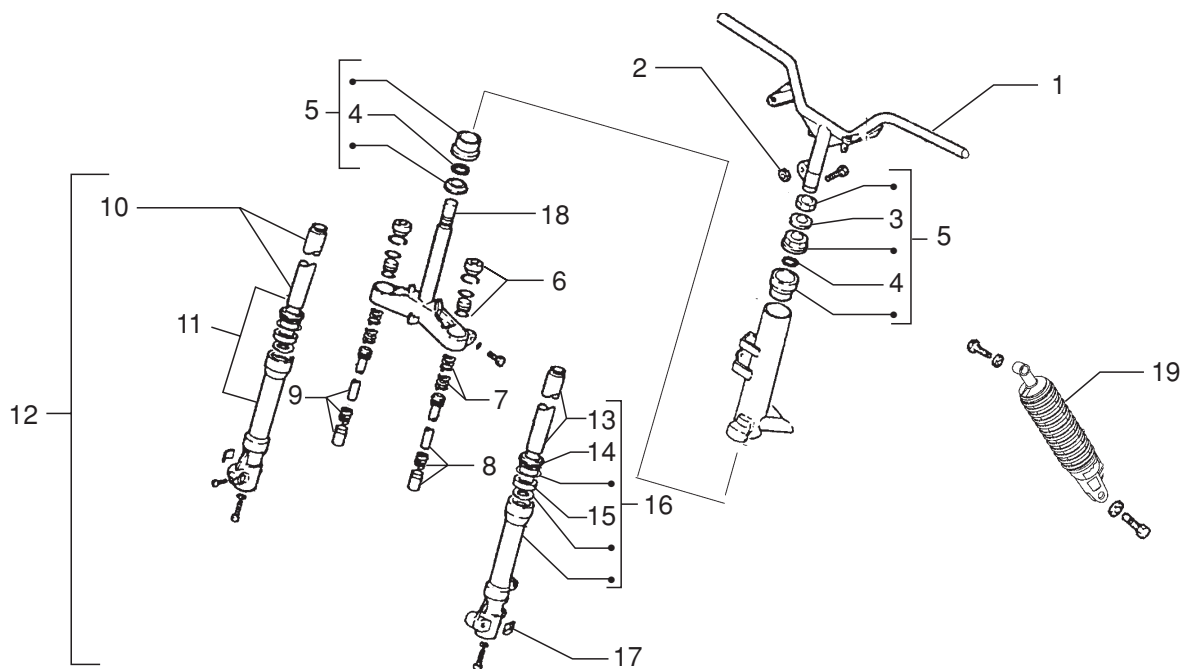

Pos Loc Pos Ps Pos	Numero Number Número Número Nummer	Q.tà Q.ty Q.té Cant M.ge	Nota Note Note Nota Anm.	Descrizione	Description	Désignation	Beschreibung	Descripció
1	22-22381-052	1		Manubrio	Handlebars	Guidon	Lenker	Manillar
2	13-21020	1		Dado metalblock M10x1,25	Nut metalblock M10x1,25	Ecrou metalblock M10x1,25	Mutter metalblock M 10 x 1,25	Tuerca metalblock M10x1,25
3	27-73790	1		Rondella per serie sterzo	Washer steering gear assy.	Rondelle mecanisme de direction	U.Scheibe lenkgruppe	Arandela grupo de dirección
4	28-87650	2		Sfera 3/16	Ball 3/16	Bille 3/16	Kugel 3/16	Bola 3/16
5	28-06760	1		Serie sterzo	Steering set	Série direction	Lenkradsatz	Serie dirección
6	29-01871	2		Tappi c/anelli	Plugs with rings	Bouchons avec bagues	Stopfen mit Ringen	Tapóns con anillos
7	22-52781	2		Molla forcella	Fork spring	Ressort fourche	Gabelfeder	Muelle horquilla
8	10-91100	1		Asta sx completa	LH rod assembly	Tige gauche compl.	linker Stab kompl.	Varilla izquierda completa
9	10-91101	1		Asta dx completa	RH rod assembly	Tige D. compl.	rechte Stangeneinheit	Varilla derecha completa
10	29-40451	1		Tubo dx forcella	Fork RH rod	Tige droit fourche	rechter Gabelschaft	Vástago derecho horquilla
11	16-18642	1		Gamba dx completa	RH leg assembly	Tube D. compl.	Rechte Beineinheit	Pata derecha completa
12	15-04000	1		Forcella completa	Stirrup assy.	Fourchette compl.	Schaltgabel, Kompl.	Horquilla compl.
12	15-04003-800	1	LIMITED	Forcella completa	Stirrup assy.	Fourchette compl.	Schaltgabel, Kompl.	Horquilla compl.
13	29-40452	1		Tubo sx forcella	Fork LH tube	Tige gauche fourche	linker Gabelschaft	Tubo izquierdo horquilla
14	10-67491	2		Parapolvere forcella	Fork dust cover	Pare-pous. fourche	Gabelstaubdeckel	Guardapolvo horquilla
15	10-41350	2		Paraolio forcella	Fork oil seal	Défecteur d'huile fourche	Gabelölabdichtung	Guardagotas horquilla
16	16-18372	1		Gamba sx completa	LH leg assembly	Tube G. compl.	Linke Beineinheit	Pata izquierda completa
17	25-58140	2		Plastrino Marzocchi	Marzocchi plate	Plaquette marzocchi	Marzocchi Plättchen	Placa Marzocchi
18	12-09771	1		Crociera c/cannotto	Cross with tube	Croisillon	Gelenkkreuz mit Rohr	Cruceta con manguito
19	10-03480	1		Ammortizzatore	Damper	Amortisseur	Stoßdämpfer	Amortiguador

Tav.13

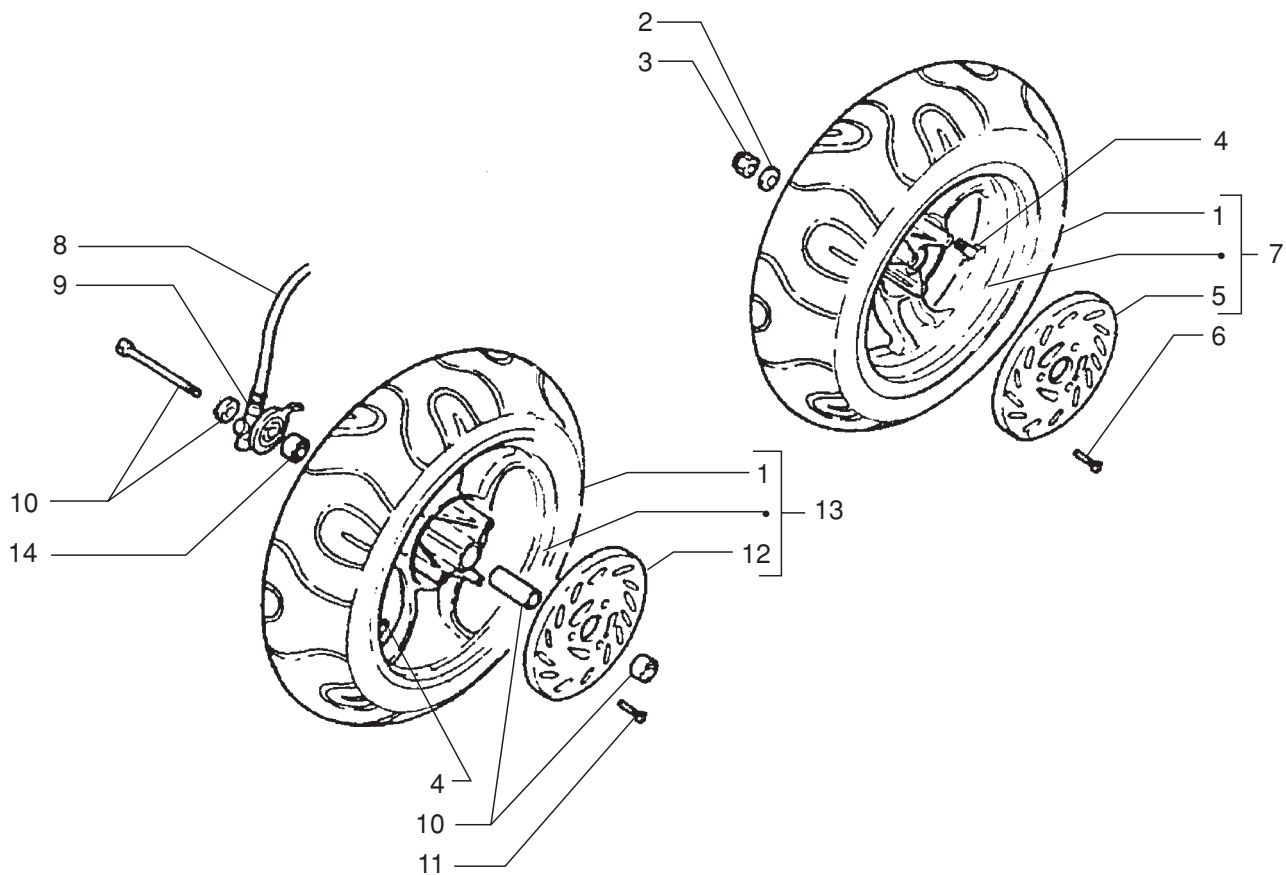

Pos Loc Pos Ps Pos	Numero Number Numéro Número Nummer	Q.tà Q.ty Q.té Cant M.ge	Nota Note Note Nota Anm.	Descrizione	Description	Désignation	Beschreibung	Descripción
1	12-80550	2	LC	Copertura 130/60-13 tass	Tyre 130/60-13 tass	Pneu 130/60-13 tass	Abdeckung 130/60-13 tass	Cubierta 130/60-13 tass
1	12-80551	2	K	Copertura 130/60-13 slick	Tyre 130/60-13 slick	Pneu 130/60-13 slick	Abdeckung 130/60-13 slick	Cubierta 130/60-13 slick
1	12-80534	2	LIMITED	Copertura anteriore 120/70-13	Front tyre 120/70-13	Pneu AV. 120/70-13	Abdeckung 120/70-13	Cubierta del. 120/70-13
1	12-80549	2	LIMITED	Copertura posteriore 130/60-13	Rear tyre 130/60-13	Pneu AR. 130/60-13	Abdeckung 130/60-13	Cubierta tras. 130/60-13
2	27-61570	1		Rondella inox	Washer Inox	Rondelle Inox	U.Scheibe Inox	Arandela Inox
3	13-29650	1		Dato autofren. M14x1,5	Locknut M14x1,5	Ecrou autobloquant M14x1,5	Selbstsichernde Mutter M14x1,5	Tuerca cierre automático M14x1,5
4	31-10000	2		Valvola aria tbl.	Tubeless valve	Valve pour tubeless	Ventil für schlauchlosen Reifen	Válvula para tubeless
5	13-39300	1		Disco freno posteriore	Rear brake disk	Disque frein arrière	Hinterbremscheibe	Disco freno trasero
6	31-64070	3		Vite flangiata 8x30	Flanged screw 8x30	Vis à brides 8x30	Flanschschraube 8x30	Tornillo rebordeado 8x30
7	27-04731-0##	1	K	Ruota post.c/disco	Rear wheel with disk	Roue arrière avec disque	Hinterrad mit Scheibe	Rueda trasera con disco
7	27-04731-057	1	LC	Ruota post.c/disco	Rear wheel with disk	Roue arrière avec disque	Hinterrad mit Scheibe	Rueda trasera con disco
8	29-14220-052	1		Trasmissione contakm	Speedom. transmiss.	Transmission compteur km.	Tachowelle	Transmisión cuenta km.
9	27-32540	1		Rinvio contakm	Odometer transmission	Renvoi compteurKM	Kilometerzählervorgelege	Reenvío CuentaKm
9	27-32541	1	LIMITED	Rinvio contakm	Odometer transmission	Renvoi compteurKM	Kilometerzählervorgelege	Reenvío CuentaKm
10	25-55830	1		Perno ruota completo	Wheel spindle assembly	Axe roue compl.	Radbolzen kompl.	Perno ruota completo
11	31-63940	3		Vite svasata M8x35	Countersunk screw M8x35	Vis à tête noyée M8x35	Senkschraube M8 x 35	Tornillo avellanado M8x35
12	13-39290	1		Disco freno anteriore	Front brake disk	Disque Frein AV.	Vordere Bremscheibe	Disco freno del.
13	27-01471-9##	1	K	Ruota ant.c/Disco	Front wheel with disk	Roue avant à Disque	Vorderrad mit Scheibe	Rueda delantera con disco
13	27-01471-957	1	LC	Ruota ant.c/Disco	Front wheel with disk	Roue avant à Disque	Vorderrad mit Scheibe	Rueda delantera con disco
13	27-01476-057	1	LIMITED	Ruota ant.c/Disco	Front wheel with disk	Roue avant à Disque	Vorderrad mit Scheibe	Rueda delantera con disco
14	13-82550	1	LIMITED	Distanziale	Spacer	Entretoise	Distanzstück	Distanciador

Tav. 14

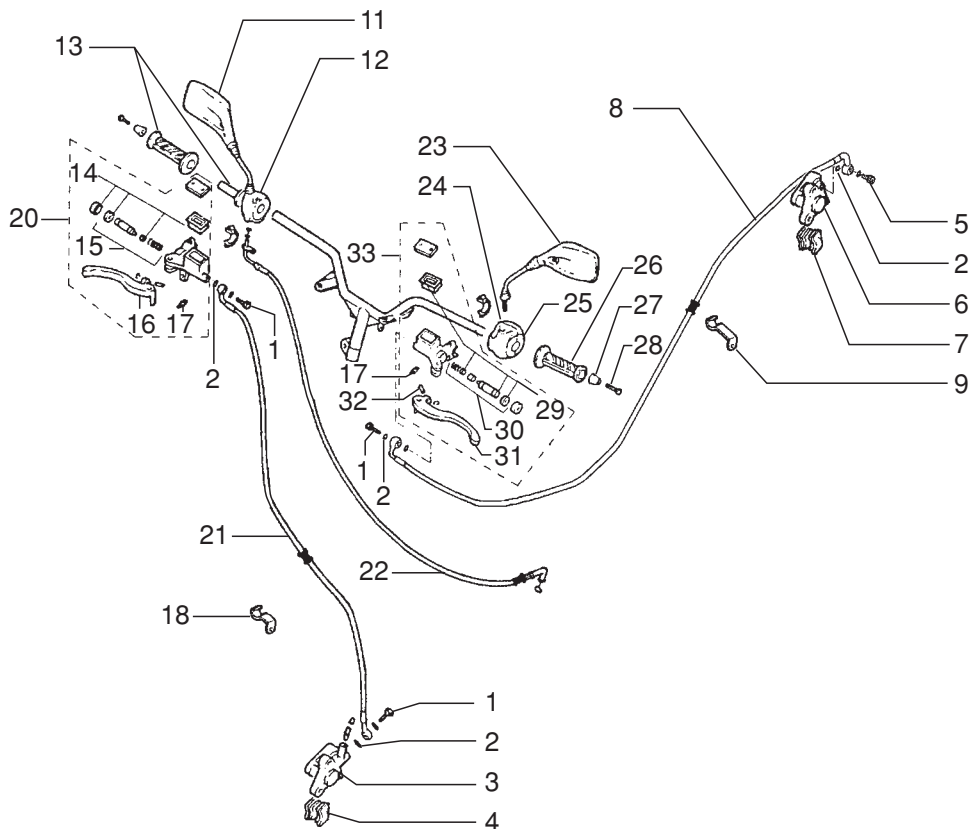

Pos Loc Ps Pos	Numero Number Numéro Número Nummer	Q.tà Q.ty Q.té Cant M.ge	Nota Note Note Nota Anm.	Descrizione	Description	Désignation	Beschreibung	Descripción
1	11-65040	3		Bullone forato	Pierced bolt	Boulon avec trou	Bolzen	Tornillo
2	16-50510	8		Rondella 10x15x1 rame	Copper washer 10x15x1	Rondelle en cuivre 10x15x1	Kupfer U.Scheibe 10x15x1	Arandela de cobre 10x15x1
3	25-03050	1		Pinza freno anteriore	Front disk brake caliper	Etrier de frein AV.	Bremszange-Scheibe	Pinza freno del.
4	25-25240	1		Pastiglie freno ant.	Front brake pads	Pastill. de freins AV.	Vorderbremsbelag	Pastillas frenos del.
5	11-65030	1		Vite di sfriato	Drain screw	Vis de vidange	Entlüfterschraube	Tornillo de ventilación
6	25-03051	1		Pinza freno posteriore	Rear disk brake caliper	Etrier de frein AR.	Bremszange	Pinza del freno tras.
7	25-25370	1		Pastiglie freni	Brake pads	Pastill. de freins	Bremsbelag	Pastillas frenos
8	29-09571-052	1		Tubo freno posteriore	Rear brake tube	Tuyau du frein AR.	Hintere Bremsleitung	Tubo freno trasero
9	25-24580	1		Passatubo	Grommet	Passe-tube	Rohrdurchgang	Pasa-tubo
11	28-94490	1		Specchio dx	RH mirror	Rétroviseur D.	rechter Spiegel	Retrovisor derecho
12	13-36430	1		Dispositivo destro	Right device	Dispositif droit	Rech. Schalterelement	Dispositivo der.
13	12-55312	1		Comando gas c/manopole	Handle control	Commande accélérateur poignées	Gasbetätigung mit Griff	Mando gas con pomos
14	20-04991	1		Kit guarnizioni pompa ant.	Front master cyl. packings kit	Jeu joints maître cyl. AV.	Dichtungensatz Vorderhauptbremszylinder	Grupo juntas bomba del.
15	20-05061	1		Kit pistoncino pompa ant.	Piston kit front master cyl.	Kit piston. maître cyl. AV.	Kolbensatz vorderhauptbremszylinder	Kit pistón bomba del.
16	21-27090	1		Leva freno anteriore	Front brake lever	Lev. frein AV.	Vorderradbremshebel	Palanca freno del.
17	18-87000	2		Interruttore stop	Stop switch	Interrupteur stop	Stopschalter	Interruptor stop
18	15-14600	1	LIMITED	Passacavo	Grommet	Passe-tube	Rohrdurchgang	Pasa-tubo
20	21-02440	1		Pompa freno anteriore	Fr. brake master cylinder	Mâitre cylindre fr. AV.	Hauptbremszylinder Vorderradbremse	Bomba fr. del.
21	29-09574-052	1		Tubo freno anteriore	Front brake tube	Tuyau du frein AV.	Vordere Bremsleitung	Tubo freno delantero
22	29-14230-052	1		Trasmissione gas	Throttle transmiss.	Transmission gaz	Gaszug	Transmisión gas
23	28-94480	1		Specchio sx	LH mirror	Rétroviseur G.	linker Spiegel	Retrovisor izquierdo
24	28-98410	1		Supporto dispositivo sx	Left device support	Support dispositif gauche	Halterung link.	Soporte dispositivo izq.
25	13-36450	1		Dispositivo sinistro	Left device	Dispositif gauche	Link. Schalterelement	Dispositivo izq.
26	22-19620	1		Coppia manopole	Grips (couple)	Poignées (couple)	Handgriffpaar	Manecilla (juego)
27	29-11971	2		Terminale manopola	Hand grip end	Extrémité poignée	Griffendteil	Parte final pomo
28	31-38010	2		Vite t.c.c.e. M6x25	Screw t.c.c.e. M6x25	Vis t.c.c.e. M6x25	Schraube t.c.c.e. M6x25	Tornillo t.c.c.e. M6x25
29	20-06011	1		Kit guarnizioni pompa post.	Rear master cyl. packings kit	Jeu joints maître cyl. AR.	Dichtungensatz hinterhauptbremszylinder	Grupo juntas bomba tras.
30	20-08320	1		Kit pistoncino pompa post.	Piston kit rear master cyl.	Kit piston. maître cyl. AR.	Kolbensatz hinterhauptbremszylinder	Kit pistón bomba tras.
31	21-25530	1		Leva freno post.	Rear brake control lever	Levier commande frein AR.	Hinterradbremshebel	Palanca mando freno trasero
32	31-96670	1		Bullone M10x1,25x45	Bolt M10x1,25x45	Boulon M10x1,25x45	Bolzen M10x1,25x45	Tornillo M10x1,25x45
33	21-02520	1		Pompa freno posteriore	Rear brake cylinder	Mâitre cylindre frein ar.	Hauptbremszylinder Hinterradbremse	Bomba freno trasero

Tav.15

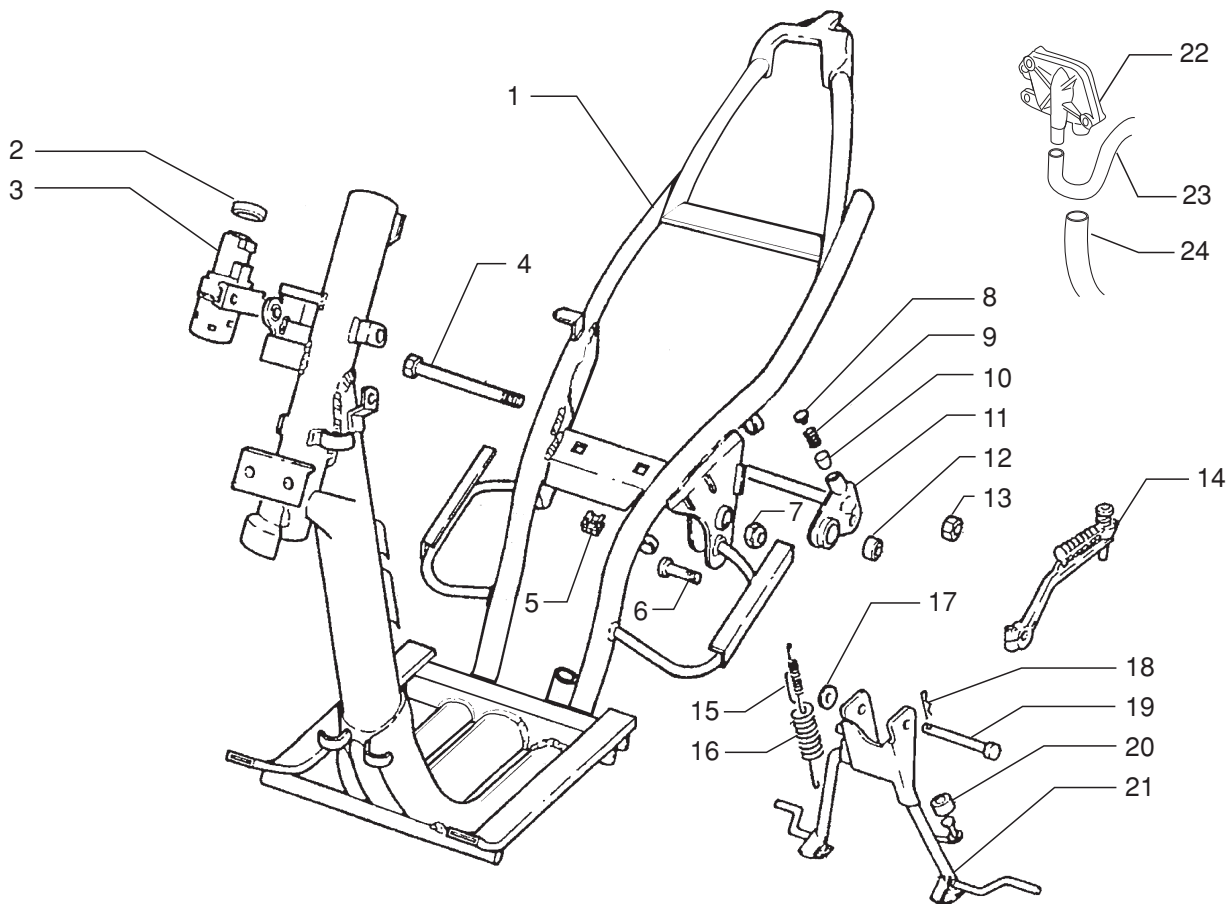

Pos Loc Pos Ps Pos	Numero Number Número Número	Q.tà Q.ty Q.té Cant M.ge	Nota Note Note Nota Anm.	Descrizione	Description	Désignation	Beschreibung	Descripción
1	29-02910-052	1		Telaio	Frame	Cadre	Rahmen	Chasis
1	29-02914-052	1	EURO 2	Telaio	Frame	Cadre	Rahmen	Chasis
2	15-66700	1		Frontalino bloccasterzo	Cap-steering wheel lock	Portillon blocage de direction	Klappe lenkradschloß	Tapa bloque del volante
3	28-03580	1		Serie serrature	Security lock set	Collect. serrures	Schloss Satz	Serie cerraduras
4	25-52520	1		Perno motore	Engine pin	Axe moteur	Motorbolzen	Perno motor
5	13-22110	1		Dado in gabbia	Nut in cage	Ecrou en cage	Mutter im Käfig	Tuerca en jaula
6	25-55660	1		Perno supporto motore	Engine mounting pin	Axe support moteur	Motorhalterzapfen	Perno soporte motor
7	13-21020	1		Dado metalblock M10x1,25	Nut metalblock M10x1,25	Ecrou metalblock M10x1,25	Mutter metalblock M 10 x 1,25	Tuerca metalblock M10x1,25
8	29-01880	1		Tappo per molla	Spring plug	Bouchon pour ressort	Federstopfen	Tapón para muelle
9	22-38510	1		Molla antivibrazioni	Antivibrating spring	Ressort antivibratile	schwingungsdämpfende Feder	Muelle antivibraciones
10	25-91530	1		Portamolla	Spring holder	Porte-ressort	Federhalter	Portamuelle
11	28-98640-8	1		Supporto motore c/silent-block	Engine support w. Silentbloc	Support du moteur av. Silent block	Motorlagerung m. Puffer	Soporte del motor c. Silent block
12	28-91360	1		Silent-block	Silentbloc	Silent block	Puffer	Silent block
13	13-21120	1		Dado autobl.M12x1,25	Locknut M12x1,25	Ecrou autobloquant M12x1,25	selbstsichernde Mutter M 12 x 1,25	Tuerca cierre automático M12x1,25
14	21-27600	1		Leva messa in moto	Start. lever	Lev.du dém.	Kickstarterhebel	Palanca de arranque
15	22-47021	1		Molla interna	Spring	Ressort	Feder	Muelle
16	22-47020	1		Molla esterna	Spring	Ressort	Feder	Muelle
17	27-64520	1		Rondella in gomma	Rubber washer	Rondelle en caoutchouc	Gummiunterlegscheibe	Arandela de goma
18	12-81980	1		Copiglia	Split pin	Goupille	Splint	Grupilla
19	25-41920	1		Perno cavalletto	Stand pin	Axe béquille	Kippständerzapfen	Perno caballete
20	16-29480	1		Protezione cavalletto	Stand pad	Cosse	Ständerschuh	Calza de goma
21	12-35730-052	1		Cavalletto	Central stand	Béquille	Kippständer	Caballete
22	31-15010	1	EURO 2	Valvola AIS	AIS Valve	Soupape AIS	Ventil AIS	Válvula AIS
23	29-15846	1	EURO 2	Tubo filtro-Valvola AIS	Pipe Filter box-AIS Valve	Tuyau Boîtier filtre-Soupape AIS	Leitung Sicherungskasten-Ventil AIS	Tubo caja del filtro-Válvula AIS
24	29-15845	1	EURO 2	Tubo marmitta-Valvola AIS	Pipe Silencer-AIS Valve	Tuyau Silencieux-Soupape AIS	Leitung Auspufftopf-Ventil AIS	Tubo Silenciador-Válvula AIS

Tav.16

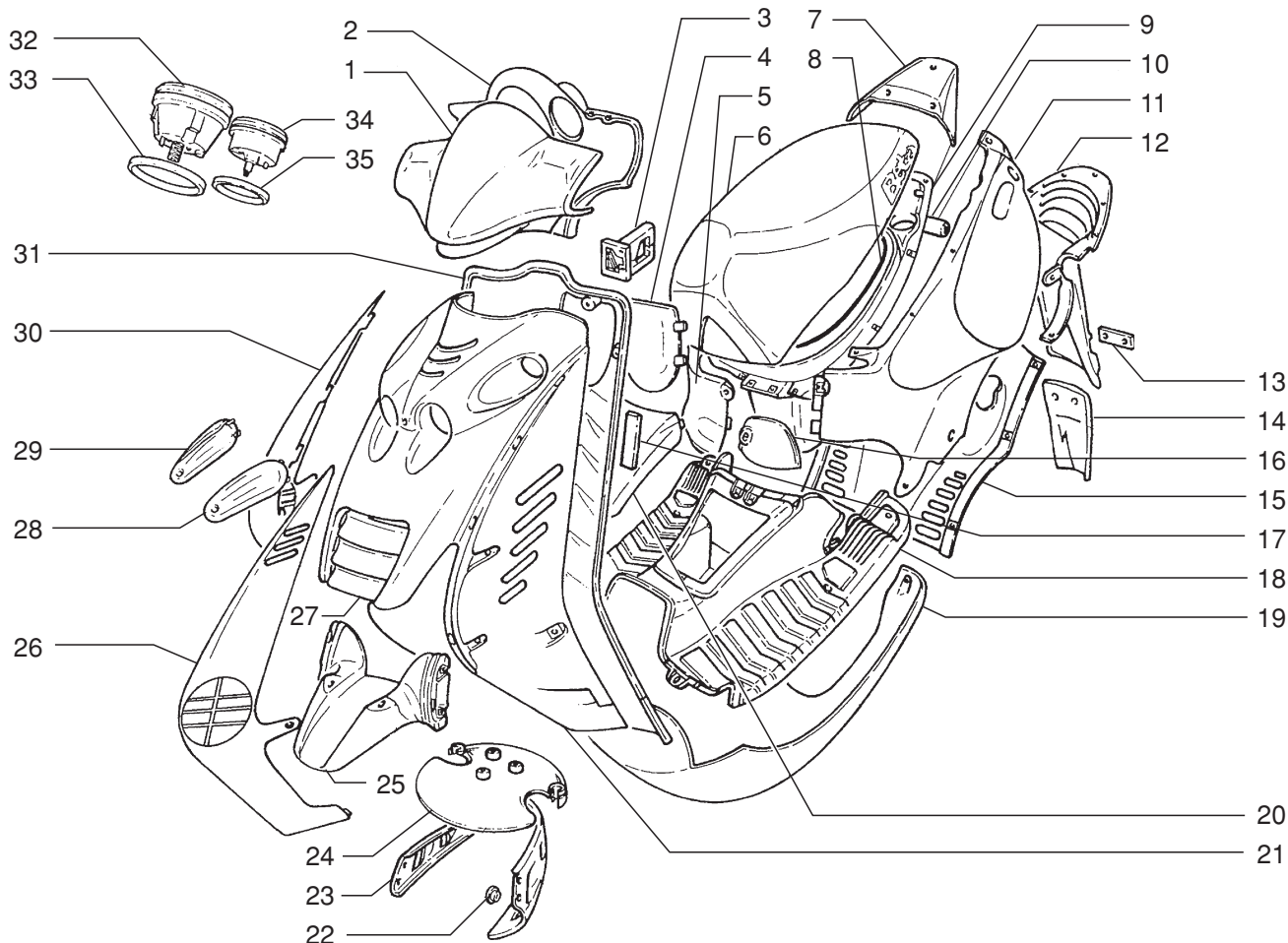

Pos Loc Ps Pos	Numero Number Número Número	Q.tà Q.ty Q.té Cant M.ge	Nota Note Note Nota Anm.	Descrizione	Description	Désignation	Beschreibung	Descripción
1	12-93360-***	1		Cupolino	Headlight fairing	Carénage	Fahrtwindschutz	Cupula
2	25-91591-052	1		Coperchio manubrio	Handlebars shell	Couvercle guidon	Lenkerdeckel	Tapa manillar
3	16-17560-052	1		Gancio portaborse	Bags hook	Crochet pour sac	Taschenhaltehaken	Gancho portabolsas
4	28-94291-052	1		Sportellino acqua	Water door	Portillon eau	Wasserbehälterklappe	Portezuela agua
5	15-22340-***	1		Fiancata dx.	Fairing,RH.	Carenage dr.	Seitenverkleidung rechts	Carenado izq.
6	28-01683	1		Sella	Seat	Siege	Sattel	Sillin
7	12-54340-***	1		Codino	Tail	Queue	Verkleidungsendstück	Colín
8	16-71480	1		Guarnizione sotto sella	Undersaddle gasket	Joint dessous de selle	Dichtung für Sattelunterteil	Junta debajo sillin
9	12-55770-052	1		Contentitore casco	Helmet container	Logement casque	Sturzhelmbehälter	Alojamiento casco
10	28-03580	1		Serie serrature	Security lock set	Collect. serrures	Schloss Satz	Serie cerraduras
11	15-22350-***	1		Fiancata sx.	Fairing, LH.	Carenage gauche	Seitenverkleidung Links	Carenado izq.
12	25-19690-052	1		Parafango posteriore	Rear mudguard	Garde-boue AR.	Hinterradkofflülge	Guardabarros tras.
13	12-33050	1		Catadiottro	Reflector	Catadioptré	Rückstrahler	Catafaro
14	16-41650-052	1		Grembialina posteriore	Rear protective sheet	Tôle de protection AR.	Seitenschutzblech, hinten, rechts	Chapa de protección tras.
15	25-24650-052	1		Passaruota posteriore	Rear wheelhouse	Passage roue AR.	Hinterradkasten	Pasa-rueda trasero
16	28-94292-052	1		Sportellino attrezzi	Toolbox flap	Abattant du coffre	Werkzeug klappe	Puerta herramientas
17	12-56520-052	1		Coperchio vano ispezione	Inspection compartment cover	Couvercle inspection	Kontrollraumdeckel	Tapa cavidad inspección
18	25-33260-052	1		Pedana poggiapiedi	Footrest passenger	Repose-pieds passager	Fussrasten für sozious	Reposapiés pasajero
19	25-99520-***	1		Puntone	Rod	Barre	Stange	Palanca
20	12-56530-052	1		Coperchio batteria	Battery cover	Couvercle Batterie	Batterieabdeckung	Tapa batería
21	28-21990-***	1		Scudo anteriore	Front shield	Tablier AV.	Frontschild, vorne	Escudo del.
22	13-55240	1		Distanziale	Spacer	Entretaise	Distanzstück	Distanciator
23	25-24421-052	1		Paraspruzzi anteriore	Front splash guard	Pare-boue AV.	Kofflügellappen vorne	Gomas aislantes del.
24	27-79480-052	1		Paraspruzzi	Splash guard	Pare-boue	Kofflügellappen	Gomas aislantes
25	25-14460-***	1		Parafango anteriore	Front mudguard	Garde boue AV.	Vorderradkofflülge	Guardabarros anterior
26	25-94631-***	1		Preso aria scudo sx	Air intake shield, L.H.	Prise d'air tablier g.	Frontschild Luftzufuhr links	Toma de aire escudo izq.
27	16-45620-052	1		Griglia radiatore	Radiator grille	Calandre	Kühlergrill	Reja del radiador
28	25-87041	1		Trasparente Lampeggiatore SX	RH turn signal lens	Transparent clignotant G.	Blinkerkappe links	Transparente intermitente izq.
29	25-87040	1		Trasparente Lampeggiatore DX	RH turn signal lens	Transparent clignotant D.	Blinkerkappe rechts	Transparente intermitente der.
30	25-94630-***	1		Preso aria scudo dx	Air intake shield, R.H.	Prise d'air tablier d.	Frontschild Luftzufuhr rechts	Toma de aire escudo der.

Tav.16

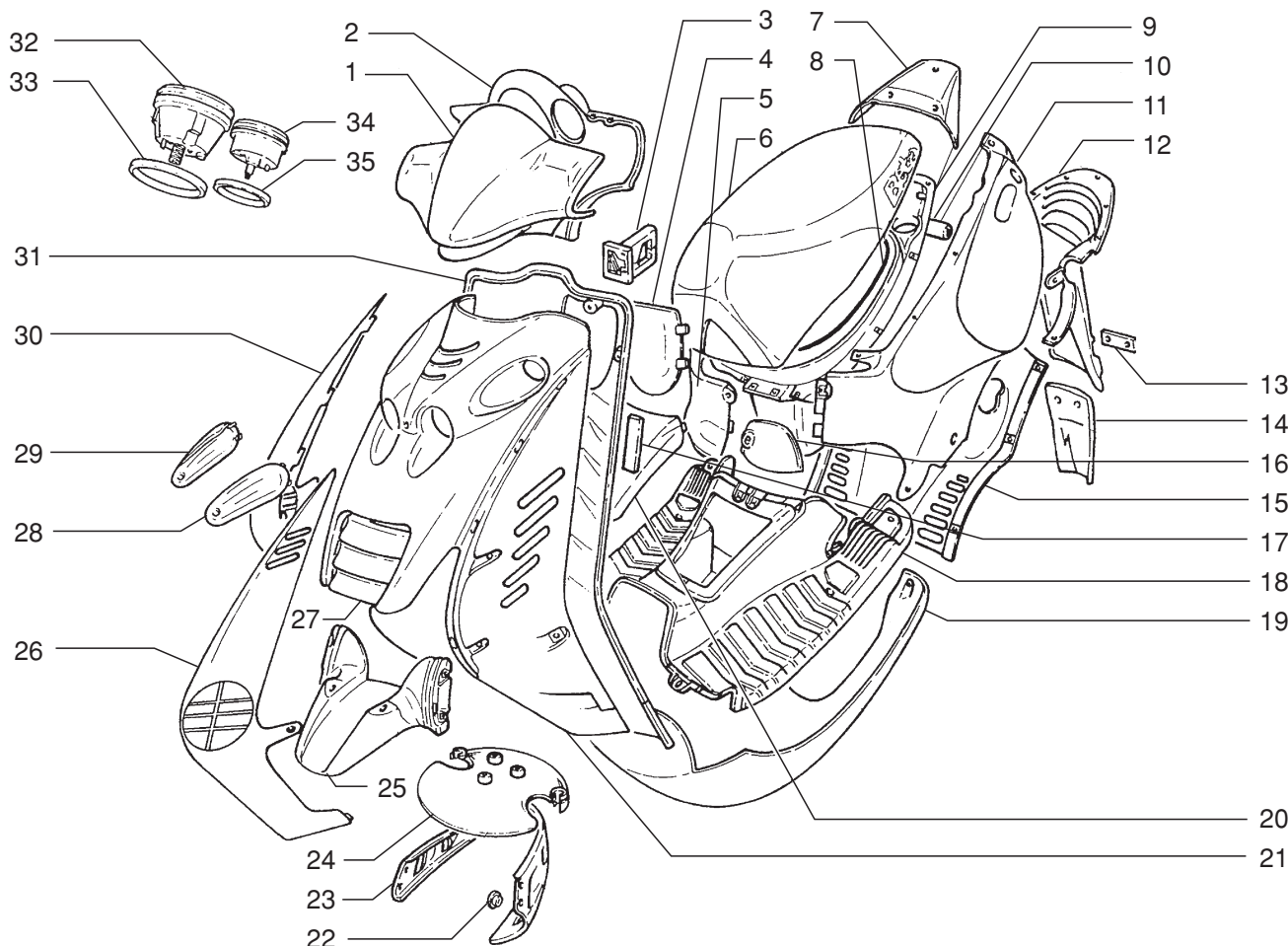

Pos Loc Pos Ps Pos	Numero Number Número Número	Q.tà Q.ty Q.té Cant M.ge	Nota Note Note Nota Anm.	Descrizione	Description	Désignation	Beschreibung	Descripción
31	25-23740-052	1		Paragambe	Leg-protection	Pare-jambes	Beinschutz	Protección de piernas
32	28-97766	1		Strumento kontakm	Odometer	Instrum. compte-km	Tachanlage	Instrum. cuenta km
33	16-29420	1		Gommino contaKM	Odometer gasket	Joint caoutchouc compteurKM	Gummidichtung für Kilometerzähler	Junta de goma cuentaKM
34	28-97731	1		Strumento livello benzina	Fuel level gauge	Jauge d'essence	Kraftstoffanzeige	Indicador de nivel de combustible
35	16-29430	1		Gommino Strumento benz.	Fuel level gauge gasket	Joint caoutchouc lauge ess.	Gummidichtung für Kraftstoffanzeige	Junta indic. combust.

Particolari non figuranti - Not illustrated parts - Pièces non illustrées - Nicht abgebildete bestandteile - Piezas no ilustradas

20-08160	1			Kit trasformazione 65cc	Transformation kit 65cc	Kit transformation 65cc	Umwandlungssatz 65cc	Kit transformación 65cc
33-02270	1			Gruppo variat.c/frizione	Variator unit with clutch	Groupe variat./embray.	Variatoreinheit mit Kupplung	Grupo variador con embrague
33-02300	1			Pistone completo d.40,5	Piston set d.40,5	Piston compl. d.40,5	Kolben, kompl. d.40,5	Pistón, compl. d.40,5
33-02320	1			Cilindro con pistone	Cylinder with piston	Cylindre avec piston	Zylinder mit Kolben	Cilindro con pistón
11-05660	1			Borsa attrezzi	Tool roll	Trousse à outils	Werkzeugtasche	Bolsa herramientas
13-31435-050	1	K		Serie decal. x ARK marrone/blu	Decalcomania set for ARK brown/blue	Série decalco pour ARK marron/bleu	Abziehbildreihe für ARK braun/blau	Serie calcomanías para ARK marrón/azul
13-31435-063	1	K		Serie decal. x ARK giallo/nero	Decalcomania set for ARK yellow/black	Série decalco pour ARK jaune/noir	Abziehbildreihe für ARK gelb/schwarz	Serie calcomanías para ARK amarillo/negro
13-31435-097	1	K		Serie decal. x ARK bianco/rosso	Decalcomania set for ARK white/red	Série decalco pour ARK blanc/rouge	Abziehbildreihe für ARK weiß/rot	Serie calcomanías para ARK blanco/rojo
13-31449-000	1	KAT		Decalco "catalyzer"	Decalcomania "catalyzer"	Décalcomanie "catalyzer"	Abziehbild "catalyzer"	Calcomania "catalyzer"
13-31601-800	1	K		Serie decal. x ARK argento/blu	Decalcomania set for ARK silver/blue	Série decalco pour ARK argent/bleu	Abziehbildreihe für ARK silber/blau	Serie calcomanías para ARK plata/azul
13-31603-800	1	LC		Serie decal. x ARK LC nero	Decalcomania set for ARK LC black	Série decalco pour ARK LC noir	Abziehbildreihe für ARK LC schwarz	Serie calcomanías para ARK LC negro
13-31605-800	1	LC		Serie decal. x ARK LC giallo	Decalcomania set for ARK LC yellow	Série decalco pour ARK LC jaune	Abziehbildreihe für ARK LC gelb	Serie calcomanías para ARK LC amarillo
13-31606-800	1	LC		Serie decal. x ARK LC Championship	Decalcomania set for ARK LC Championship	Série decalco pour ARK LC Championship	Abziehbildreihe für ARK LC Championship	Serie calcomanías para ARK LC Championship
13-31608-800	1	K		Serie decal. x ARK replica 2002	Decalcomania set for ARK replica 2002	Série decalco pour ARK replica 2002	Abziehbildreihe für ARK replica 2002	Serie calcomanías para ARK replica 2002
13-43080	1			Chiave candela	Ignition wrench	Clé à bougie	Zündkerzenschlüssel	Llave buji
28-98615-052	1			Supporto targa	Licence plate bracket	Support plaque	Nummernschildträger	Soporte placa porta matrícula

*** Legenda colori - Colours list - Légend couleurs - Farbenlegende - Leyenda a colores

032	K	Blu	Blue	Bleu	Blau	Azul
033	K-LC	Argento	Silver	Argent	Silber	Plata
049	K	Marrone	Brown	Marron	Braun	Marrón
050	K	Celeste	Light blue	Céleste	Hellblau	Azul celeste
052	K-LC	Nero	Black	Noir	Schwarz	Negro
053	LC	Rosso	Red	Rouge	Rot	Rajo
059	K	Nero opaco	Mat black	Noir opaque	Matt Schwarz	Negro mate
063	K-LC	Giallo	Yellow	Jaune	Gelb	Amarillo
097	K	Arancio	Orange	Orange	Orange	Anaranjado
098	K	Bianco perla	Pearl white	Blanc Perle	Perle Weiß	Bianco perla

Legenda colori - Colours list - Légend couleurs - Farbenlegende - Leyenda a colores

057	K	Alluminio	Aluminium	Aluminium	Aluminium	Aluminium
059	K	Nero opaco	Mat black	Noir opaque	Matt Schwarz	Negro mate

TABELLA VERNICIATURA PLASTICHE ARK BICOLORE

	CODICE, DESCR. PDODOTTO FINITO	098 ARK K BIANCO ROSSO	050 ARK K MARRONE BLU	033 ARK K BLU ARGENTO	028 ARK K GIALLO NERO	075 ARK K ARGENTO BLU	094 ARK K ARANCIO NERO	052 ARK K X-TYPE
Descrizione	Codice							
Codino sella	1254340	098 Bianco perla	049 Marrone	032 Blu	052 Nero	033 Argento	059 Nero opaco	052 Nero
Cupolino	1293360	097 Rosso fluo	050 Celeste	033 Argento	063 Giallo	075 Blu	094 Arancio	097 Rosso fluo
Fiancata destra	1522340	098 Bianco perla	049 Marrone	032 Blu	052 Nero	033 Argento	059 Nero opaco	052 Nero
Fiancata sinistra	1522350	098 Bianco perla	049 Marrone	032 Blu	052 Nero	033 Argento	059 Nero opaco	052 Nero
Parafango anteriore	2514460	098 Bianco perla	049 Marrone	032 Blu	052 Nero	033 Argento	059 Nero opaco	052 Nero
Presa aria scudo DX	2594630	098 Bianco perla	049 Marrone	032 Blu	052 Nero	033 Argento	059 Nero opaco	052 Nero
Presa aria scudo SX	2594631	098 Bianco perla	049 Marrone	032 Blu	052 Nero	033 Argento	059 Nero opaco	052 Nero
Puntone	2599520	098 Bianco perla	049 Marrone	032 Blu	052 Nero	075 Blu	094 Arancio	097 Rosso fluo
Scudo	2821990	097 Rosso fluo	050 Celeste	033 Argento	063 Giallo	075 Blu	094 Arancio	097 Rosso fluo

	CODICE, DESCR. PDODOTTO FINITO	059 ARK LC REPLICA 2002	057 ARK LC DUOGIE REPLICA	033 ARK LC CHAMPION-SHIP	097 ARK LC ROSSO GRIGIO	097 ARK RR	052 ARK LIMITED	052 ARK LIMITED
Descrizione	Codice							
Codino sella	1254340	033 Argento	057 Alluminio	033 Argento	097 Rosso fluo	097 Rosso fluo	052 Nero	059 Nero opaco
Cupolino	1293360	059 Nero opaco	059 Nero opaco	053 Rosso	097 Rosso fluo	097 Rosso fluo	052 Nero	052 Nero
Fiancata destra	1522340	033 Argento	057 Alluminio	033 Argento	033 Argento	097 Rosso fluo	052 Nero	059 Nero opaco
Fiancata sinistra	1522350	033 Argento	057 Alluminio	033 Argento	033 Argento	097 Rosso fluo	052 Nero	059 Nero opaco
Parafango anteriore	2514460	033 Argento	057 Alluminio	033 Argento	033 Argento	033 Argento	052 Nero	059 Nero opaco
Presa aria scudo DX	2594630	033 Argento	057 Alluminio	033 Argento	033 Argento	033 Argento	052 Nero	059 Nero opaco
Presa aria scudo SX	2594631	033 Argento	057 Alluminio	033 Argento	033 Argento	033 Argento	052 Nero	059 Nero opaco
Puntone	2599520	033 Argento	057 Alluminio	033 Argento	033 Argento	033 Argento	052 Nero	059 Nero opaco
Scudo	2821990	059 Nero opaco	059 Nero opaco	053 Rosso	097 Rosso fluo	097 Rosso fluo	052 Nero	052 Nero

